



US008077044B2

(12) **United States Patent**
Nikitin et al.

(10) **Patent No.:** **US 8,077,044 B2**
(45) **Date of Patent:** **Dec. 13, 2011**

(54) **RFID TAGS WITH ENHANCED RANGE AND BANDWIDTH OBTAINED BY SPATIAL ANTENNA DIVERSITY**

(75) Inventors: **Pavel Nikitin**, Seattle, WA (US); **KVS (Venkata Kodukula) Rao**, Bothell, WA (US); **Sander Lam**, Everett, WA (US)

(73) Assignee: **Intermec IP Corp.**, Everett, WA (US)

(*) Notice: Subject to any disclaimer, the term of this patent is extended or adjusted under 35 U.S.C. 154(b) by 477 days.

(21) Appl. No.: **12/396,361**

(22) Filed: **Mar. 2, 2009**

(65) **Prior Publication Data**

US 2009/0219158 A1 Sep. 3, 2009

Related U.S. Application Data

(60) Provisional application No. 61/033,313, filed on Mar. 3, 2008.

(51) **Int. Cl.**
G08B 13/14 (2006.01)

(52) **U.S. Cl.** **340/572.7**

(58) **Field of Classification Search** **340/572.7, 340/572.1-572.6; 343/700 R**

See application file for complete search history.

(56) **References Cited**

U.S. PATENT DOCUMENTS

7,535,424 B2 *	5/2009	Henty	343/702
7,663,544 B2 *	2/2010	Thomas et al.	342/361
7,688,267 B2 *	3/2010	Hill	343/702
7,873,385 B2 *	1/2011	Boireau et al.	455/553.1
2006/0043199 A1	3/2006	Baba et al.	
2006/0174257 A1	8/2006	Arneson et al.	
2006/0273905 A1	12/2006	Choi et al.	
2007/0152830 A1	7/2007	Burr	

OTHER PUBLICATIONS

“The RFID Tag Antenna: Orientation Sensitivity;” Impinj RFID Technology Series, www.impinj.com, 2005, 2 pages.

“Two RF Inputs Make a Better RFID Tag;” Technical White Paper, Symbol—The Enterprise Mobility Company, May 2006, 2 pages.

Collins, J. “Smart Soccer Ball Misses Its Goal;” <http://www.rfidjournal.com/article/print/2029>, RFID Journal, Dec. 5, 2005, 2 pages.

Dietrich et al. “Spatial, Polarization, and Pattern Diversity for Wireless Handheld Terminals;” IEEE Transactions on Antennas and Propagation, vol. 49, No. 9, Sep. 2001, pp. 1271-1281.

* cited by examiner

Primary Examiner — Phung Nguyen

(74) *Attorney, Agent, or Firm* — Perkins Coie LLP

(57) **ABSTRACT**

Spatial antenna diversity is used with RFID tags to reduce sensitivity to multi-path fading. RFID tags can use a single multi-port chip or multiple multi-port chips. The ports of the chip or chips are coupled to separated feedpoints on one or more antennas.

31 Claims, 7 Drawing Sheets

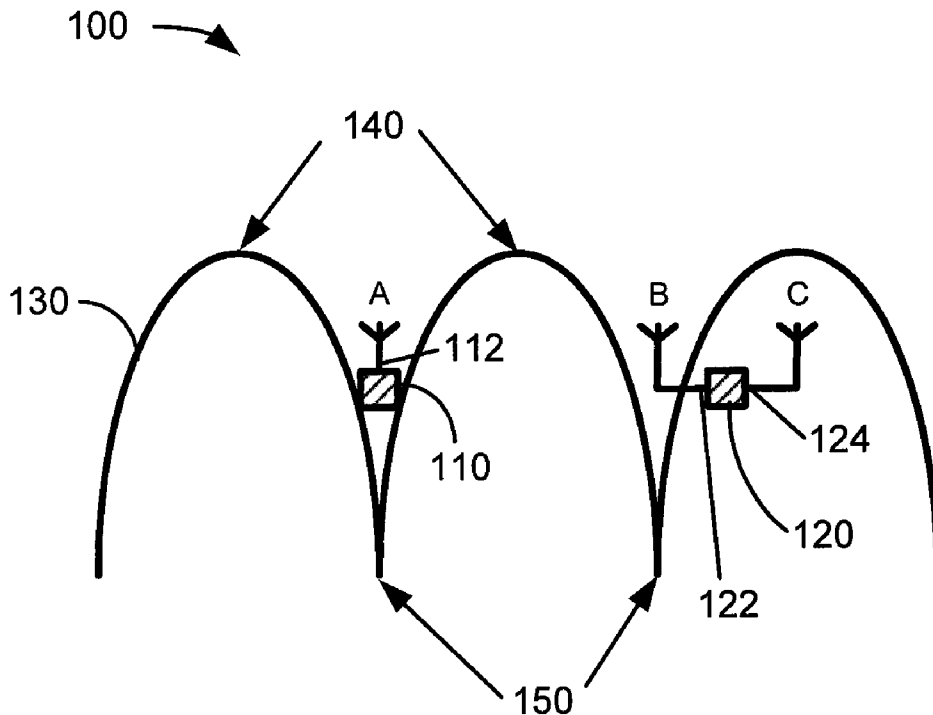

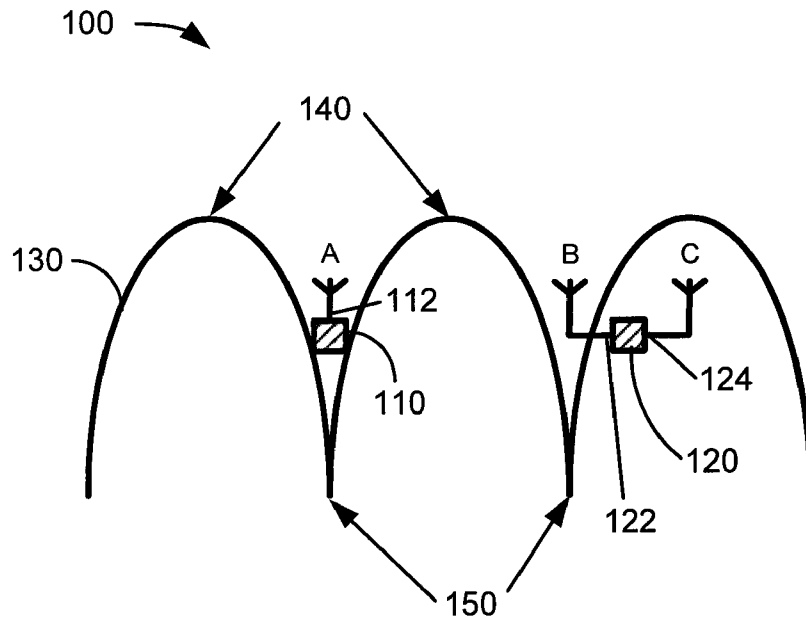

FIG. 1

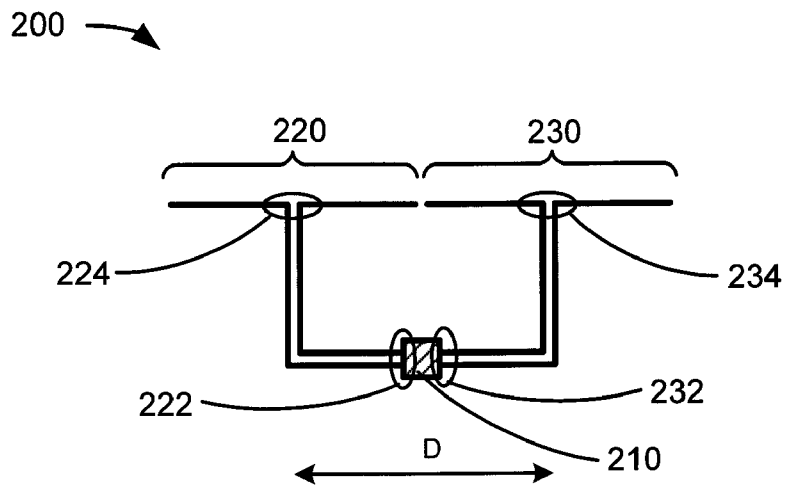

FIG. 2

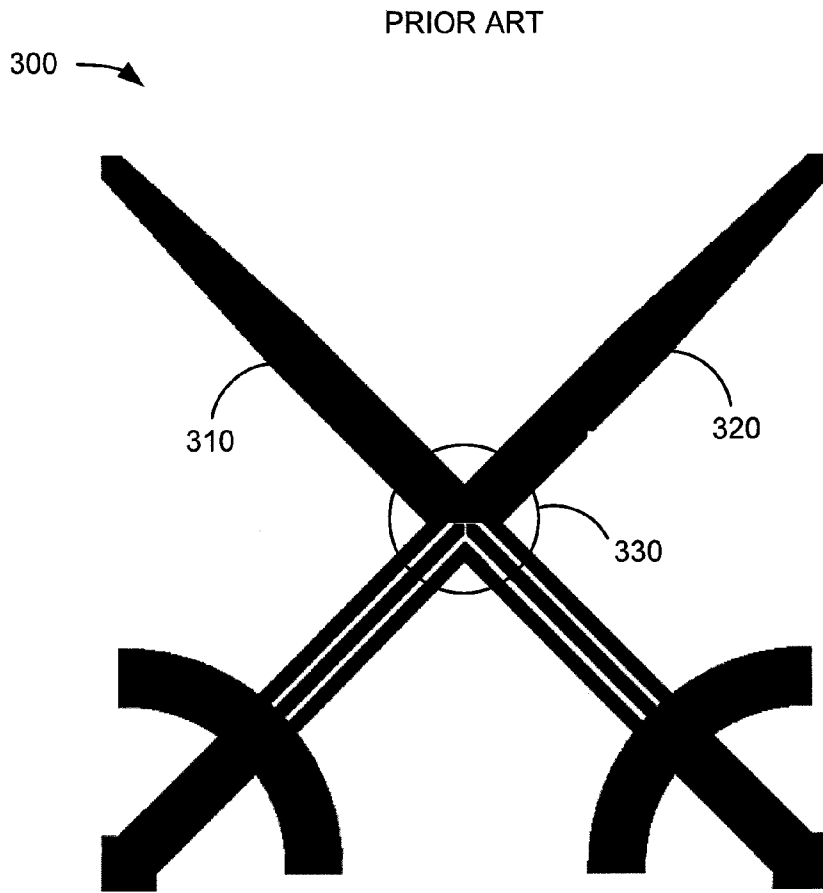

FIG. 3A

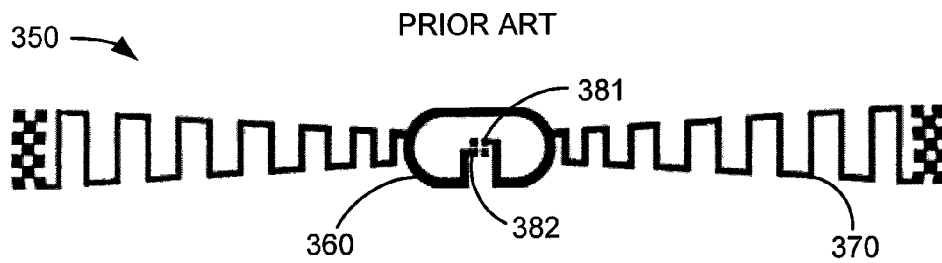

FIG. 3B

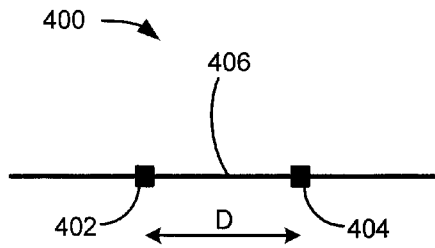

FIG. 4A

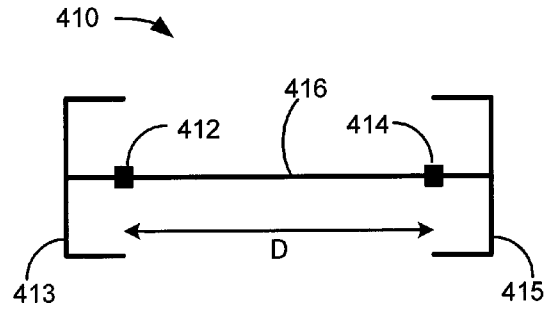

FIG. 4B

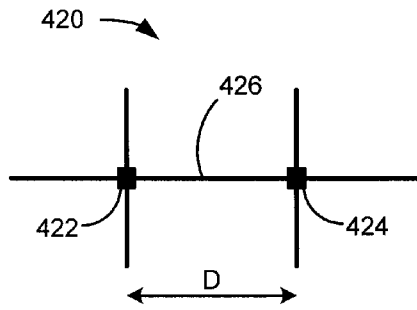

FIG. 4C

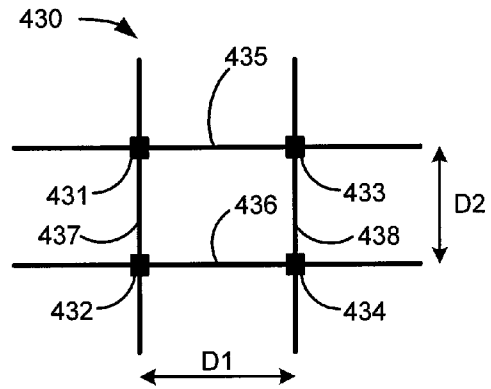

FIG. 4D

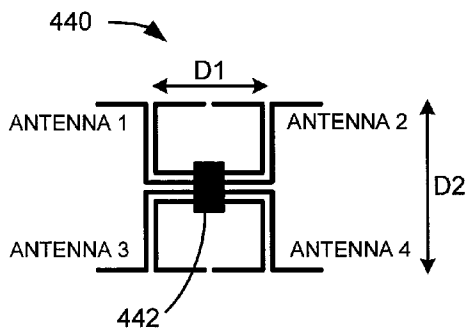

FIG. 4E

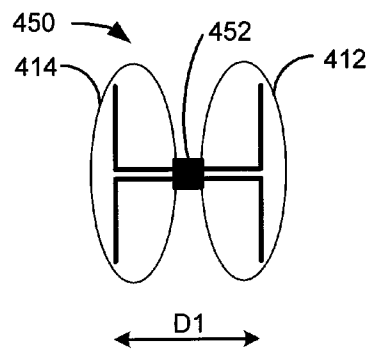

FIG. 4F

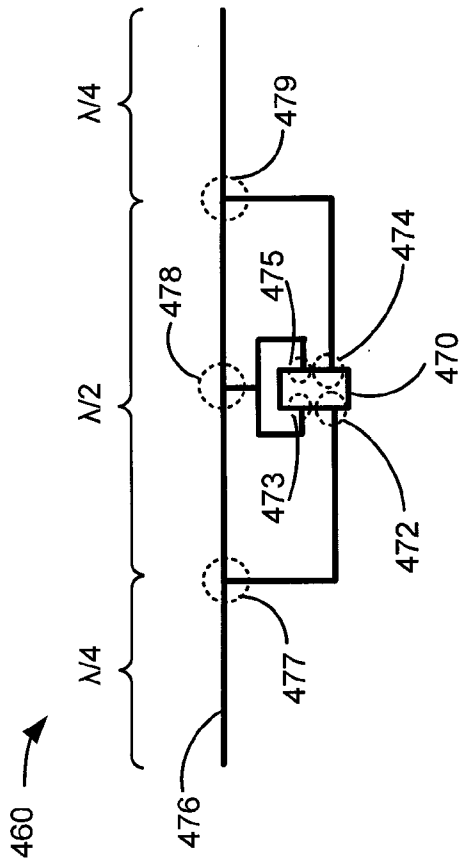

FIG. 4G

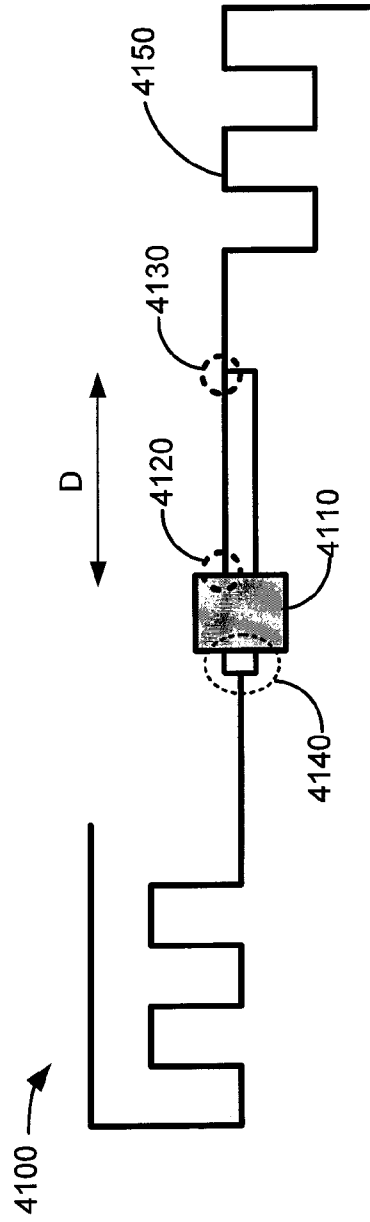

FIG. 4H

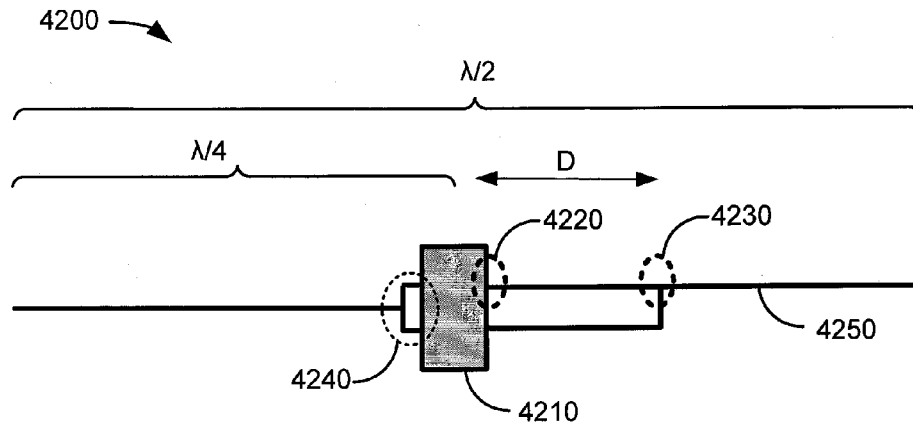

FIG. 4I

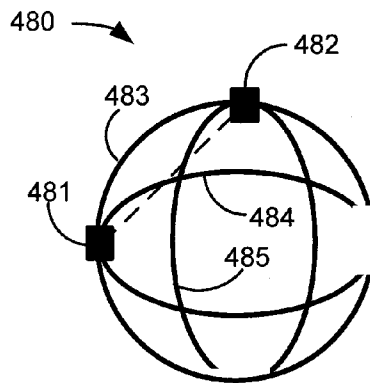

FIG. 4J

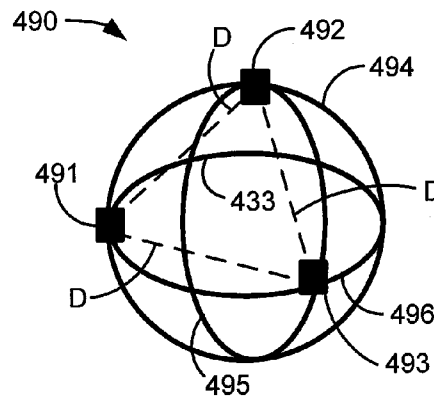

FIG. 4K

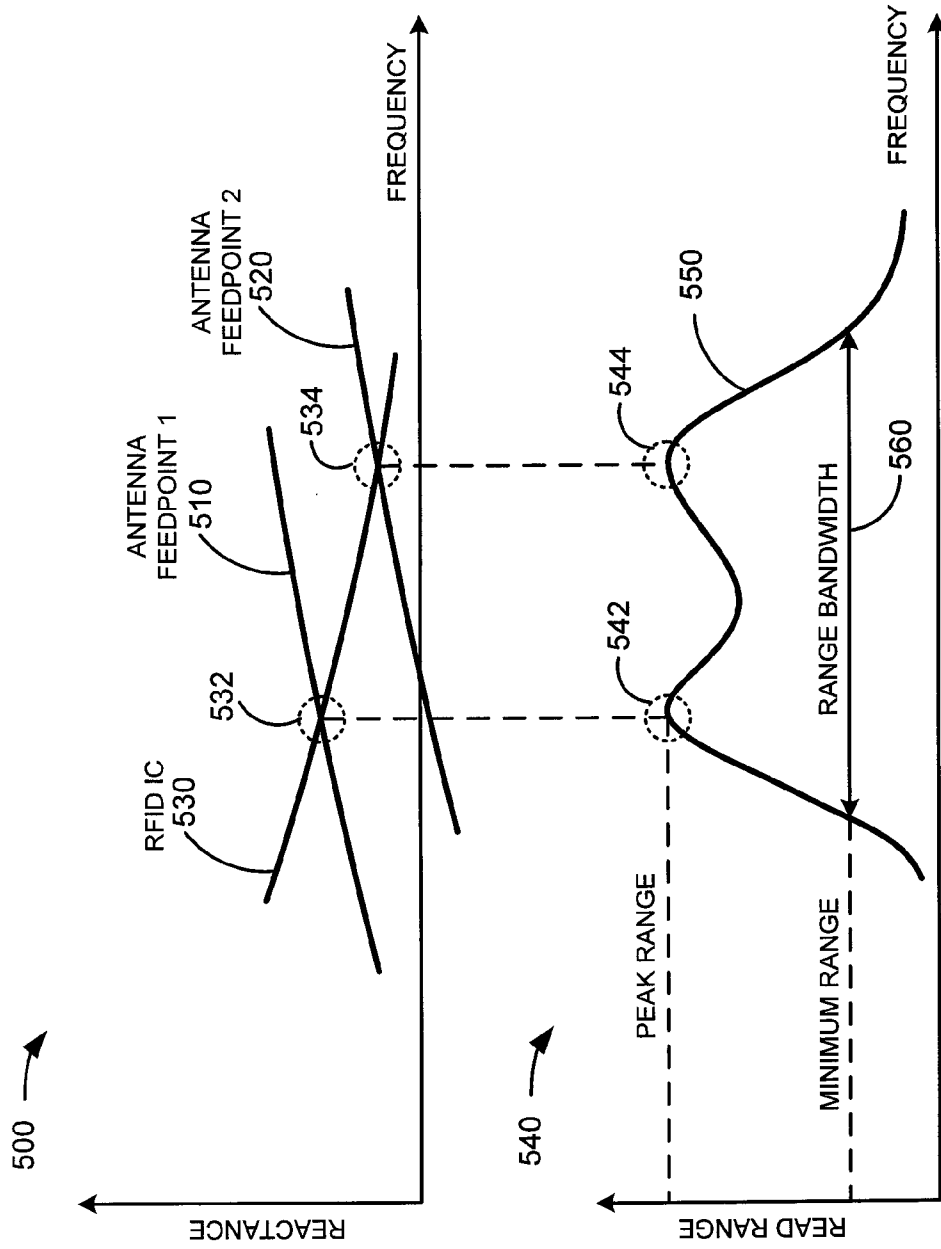

FIG. 5

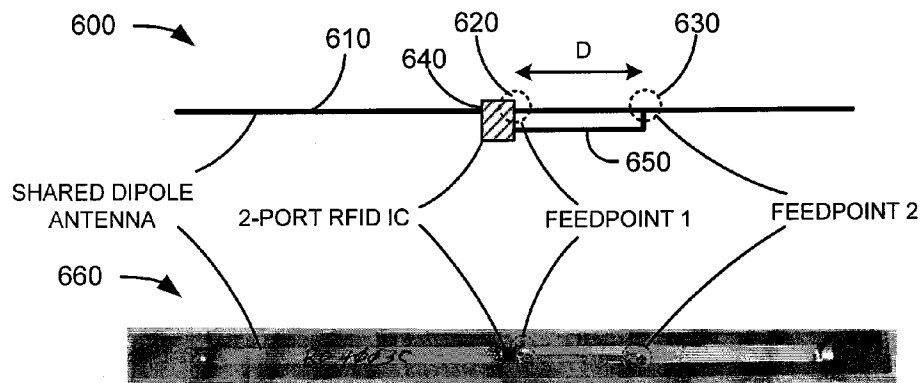

FIG. 6

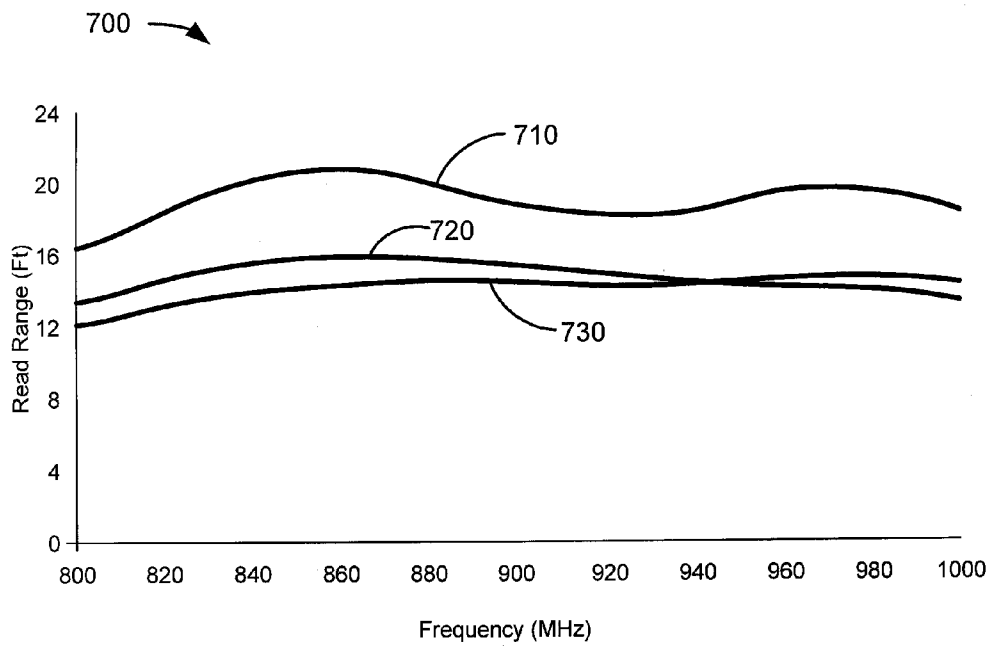

FIG. 7

RFID TAGS WITH ENHANCED RANGE AND BANDWIDTH OBTAINED BY SPATIAL ANTENNA DIVERSITY

CROSS REFERENCES

This application claims the benefit of U.S. Provisional application No. 61/033,313, entitled "RFID TAGS WITH ENHANCED RANGE AND BANDWIDTH OBTAINED BY SPATIAL ANTENNA DIVERSITY", filed Mar. 3, 2008, and is hereby incorporated by reference.

BACKGROUND

In a typical environment where RFID tags are used, RF signals transmitted by an RFID reader may take multiple paths to reach an RFID tag's antenna due to reflections of the RF waves from various objects in the propagation path, such as floors, ceilings, and walls. Due to constructive and destructive interference among the RF waves traveling different paths, electromagnetic standing wave patterns may be established. The standing wave patterns have periodic peaks and nulls that are located one quarter wavelength apart. An RFID tag's antenna essentially samples the RF field at its feedpoint. Consequently, if the RFID tag's antenna feedpoint is located at a null of the standing wave pattern, the tag will not receive the RFID reader's RF transmission and will not be powered up.

Diversity in antenna configurations, including spatial diversity, polarization diversity, pattern diversity, time diversity, and frequency diversity, has been explored in handheld radio systems, such as cellular phone systems, where both the transmitter and receiver are active devices. Diversity and/or an increase in signal power is used to provide better reliability in RF propagation environments where multipath fading can occur.

It should be noted that RFID tags are regulated by Gen 2 protocol standards and thus are not permitted to exploit signal processing to improve RF signal transmission reliability. Thus, there is a need for a system that overcomes the multipath fading problem, as well as providing additional benefits, for a passive RFID tag responding to an RFID reader's RF transmissions. Overall, the above examples of some related systems and associated limitations are intended to be illustrative and not exclusive. Other limitations of existing or prior systems will become apparent to those of skill in the art upon reading the following Detailed Description.

BRIEF DESCRIPTION OF THE DRAWINGS

FIG. 1 shows an example of how an RFID tag with spatially separated antennas is resistant to fading effects.

FIG. 2 shows an example of an RFID tag with a two-port integrated chip having two co-polarized, spatially separated antenna feedpoints.

FIG. 3 shows two examples of prior art antenna configurations used with RFID tags, each using a two-port RFID chip.

FIGS. 4A through 4K show several example embodiments of RFID tags with spatial diversity using multiple RFID integrated chips with either single or multiple ports or a single RFID chip with multiple ports.

FIG. 5 shows two graphs. The top graph shows reactance curves as a function of frequency for an RFID tag's integrated circuit chip, with an antenna at a first feedpoint and an antenna

at a second feedpoint. A corresponding graph of read range for the RFID tag as a function of frequency is shown in the bottom graph.

FIG. 6 shows a photograph of a prototype RFID tag with spatial diversity and a corresponding schematic diagram.

FIG. 7 is a graph of read range as a function of frequency comparing performance of an RFID tag with antenna spatial diversity and without antenna spatial diversity.

DETAILED DESCRIPTION

Described in detail below is a method of using spatial antenna diversity to reduce RFID tag sensitivity to multi-path fading and sensitivity to "hot" or "cold" spots on boxes or pallets. "Hot" spots are locations where the electric field strength generated by an incoming electromagnetic wave is high, and "cold" spots are locations where the strength is low. The differences in electromagnetic field strength are due to material properties of objects within the box or pallet.

Various aspects of the invention will now be described. The following description provides specific details for a thorough understanding and enabling description of these examples. One skilled in the art will understand, however, that the invention may be practiced without many of these details. Additionally, some well-known structures or functions may not be shown or described in detail, so as to avoid unnecessarily obscuring the relevant description.

The terminology used in the description presented below is intended to be interpreted in its broadest reasonable manner, even though it is being used in conjunction with a detailed description of certain specific examples of the invention. Certain terms may even be emphasized below; however, any terminology intended to be interpreted in any restricted manner will be overtly and specifically defined as such in this Detailed Description section.

An RFID reader transmits electromagnetic waves at radio frequencies. RFID tags may often receive the RF waves that have been reflected off other surfaces in the environment, such as floors, ceilings, walls, and shelves. In a typical propagation environment, standing wave patterns may be formed due to these reflections, and peaks and nulls located one quarter wavelength apart are established. In FIG. 1, an example **100** of the effect of a standing wave pattern on RFID tags **110**, **120** is shown. The standing wave pattern **130** indicates the RFID reader signal strength in space. The RF signal is at a maximum at the peaks **140** and is at a minimum at the nulls **150**. The RF signal strength at or near a null is insufficient to power an RFID tag. Neighboring peaks **140** are separated by one-half wavelength. Neighboring nulls **150** are, likewise, separated by one-half wavelength. The wavelength is determined by the wavelength at which the RFID reader transmits RF signals, typically between 800 MHz and 1000 MHz.

A feedpoint is the point that a signal appears to emanate from when an antenna is connected to a transmitter emitting a sinusoidal wave and viewed from the far field. If an RFID tag **110** has a single antenna whose feedpoint **112** is located at a null **150** of the RFID reader signal, no transfer of power from the RFID reader signal to the RFID tag will occur. In contrast, if an RFID tag **120** has two antennas **122**, **124** that are separated by one-quarter wavelength, and if one of the antennas has a feedpoint **122** located at a null **150** of the RFID reader signal, the feedpoint of the other antenna **124** will be located at a peak **140** of the reader signal. Thus, a transfer of power from the RFID reader signal to the RFID tag will still occur through antenna **124**.

The example depicted in FIG. 1 is for the case where one of the RFID tag's antennas **122** is situated at a null **150**. Alternatively, the tag's antenna may not be situated at a null **150** but near the null where the RFID reader signal strength may still not be strong enough to power the RFID tag. In this case, the tag's second antenna will not be situated at a peak **150** but near the peak. However, the combined power received at the two antennas **122, 124** is sufficient to power the RFID tag **120**.

An example of an RFID tag **200** having spatial diversity is shown in FIG. 2. The RFID tag **200** has a two-port RFID integrated circuit chip **210**. A first dipole antenna **220** is coupled to the first port **222** of the RFID chip **210**, and a second dipole antenna **230** is coupled to the second port **232** of the RFID chip **210**. Note that the first antenna **220** and the second antenna **230** are co-polarized, that is, the antennas are parallel to each other. The first antenna **220** has a feedpoint at **224**, and the second antenna **230** has a feedpoint at **234**. The distance between the feedpoints **224** and **234** is D . In a depicted embodiment, the distance D is approximately one-quarter wavelength. However, any separation between the feedpoints of two antennas may improve the performance of the RFID tag by reducing the RFID tag's sensitivity to multipath fading and/or increasing the read range of the RFID tag.

Two-port RFID integrated circuit chips designed for use with RFID tags are well-known in the art for implementing polarization diversity. For example, Impinj, Inc. manufactures two-port RFID integrated circuit chips for RFID tags. Both Impinj, Inc. and Motorola, Inc., formerly Symbol Technologies, Inc., another RFID tag manufacturer, specifically recommend using diversity polarization, where two orthogonally oriented dipole antennas are used, with one antenna coupled to each of the two ports of the IC chip. Because a dipole antenna has a null parallel to the axis of the dipole, a dipole antenna is not able to receive any electromagnetic energy that is polarized parallel to the axis of the dipole. Thus, Impinj and Symbol Technologies teach using a two-port RFID chip only with diversity polarization to eliminate the problem of antenna nulls such that an RFID tag is able to receive RF signals polarized in any direction.

FIG. 3A shows an example of an RFID tag with diversity polarization **300** having two cross-polarized antennas **310, 320** connected to a two-port RFID chip. The RFID tag **300** and two-port chip are manufactured by KSW Microtec AG and Impinj, Inc., respectively. In this configuration, one antenna is coupled to each one of the ports of the chip, but the feedpoints of the antennas are at the same location **330**. Although the cross-polarized antenna configuration is able to receive RF signals polarized in any direction, using diversity polarization does not eliminate the problem presented by an RFID tag's feedpoints being located within a null of an RF standing wave. Thus, if the feedpoints **330** are located at a null, for example, point **150** in FIG. 1, the total power received by the cross-polarized antennas will still be insufficient to power the RFID tag.

Moreover, because the footprint of the RFID tag having cross-polarized antennas **300** is so large, one port of the RFID chip is typically left unused. FIG. 3B shows an example of an RFID tag **350**. The tag antenna **370** is manufactured by RSI ID Technologies, and the two-port RFID chip **360** is manufactured by Impinj, Inc. The RFID chip **360** has four contact pads corresponding to the two ports. Only the two contact pads **381, 382** corresponding to one port of the chip **360** are attached to the linearly polarized antenna **370**. Thus, 50% of the RFID chip's capabilities are unused. However, the area occupied by an RFID tag having only one linearly polarized antenna **350** is significantly reduced from that of an RFID tag having the cross-polarized antenna configuration **300**.

Note that if the two terminal ports of a two-port RFID chip are connected together with a conducting trace such that the two terminals are short circuited, the result is that the RFID chip does not perform as well as when only one port of the chip is used to couple to a feedpoint of the RFID tag's antenna. Thus, if only one port of a two-port RFID chip is coupled to an antenna, the other port should be left unconnected.

In contrast to polarization diversity, the key to spatial diversity, using co-polarized or orthogonally polarized antennas, is that the feedpoints of the antennas must be spatially separated. Several embodiments of antenna spatial diversity are shown in FIGS. 4A through 4K with multiple spatially separated multi-port RFID chips that share a single antenna or a single multi-port chip with distinct feed points.

FIG. 4A shows a first example of spatial diversity **400** using two one-port RFID chips **402, 404**. A shared antenna **406** is coupled to both of the one-port RFID chips **402, 404**. The RFID chips **402, 404** are physically separated by a distance D so that the feedpoints of the shared antenna **406** are separated by a distance D .

FIG. 4B shows a second example of spatial diversity **410** using two one-port RFID chips **412, 414**. Similar to the above example **400**, a shared antenna **416** is coupled to both of the RFID chips **412, 414**. Again, the RFID chips **402, 404** are physically separated by a distance D so that the feedpoints of the shared antenna **406** are separated by a distance D . In this example, the portions of the antennas not shared by the ports **412, 414** take the form of stub elements **413, 415**.

FIG. 4C shows a third example of spatial diversity **420** using two two-port RFID chips **422, 424**. Both ports of the RFID chips **422, 424** are coupled to antennas. One antenna **426** is shared between the two RFID chips **422, 424**. The two-port RFID chips **422, 424** are physically separated by a distance D so that the feedpoints of the shared antenna **426** are separated by a distance D . Each of the RFID chips **422, 424** has two cross-polarized antennas coupled to the ports.

FIG. 4D shows a fourth example of spatial diversity **430** using four two-port RFID chips **431, 432, 433, 434**. Each of the two-port RFID chips **431, 432, 433, 434** has two ports which yields a total of eight ports. All eight ports are coupled to antennas. A first shared antenna **435** is coupled to one of the ports on the RFID chip **431** and one of the ports on the RFID chip **433**. A second shared antenna **436** is coupled to one of the ports on the RFID chip **432** and one of the ports on the RFID chip **434**. RFID chips **431** and **433** are separated by a distance $D1$, and chips **432** and **434** are also separated by the distance $D1$. A third shared antenna **437** is coupled to one of the ports on the RFID chip **431** and one of the ports on the RFID chip **432**. A fourth shared antennas **438** is coupled to one of the ports on the RFID chip **433** and one of the ports on the RFID chip **434**. RFID chips **431** and **432** are separated by a distance $D2$, and chips **433** and **434** are also separated by the distance $D2$. Thus, the feedpoints of the shared antennas **435, 436** are separated by the distance $D1$, and the feedpoints of the shared antennas **437, 438** are separated by the distance $D2$.

FIG. 4E shows a fifth example of spatial diversity **440** using one four-port RFID chip **440**. All four antennas, antenna **1**, antenna **2**, antenna **3**, and antenna **4** are co-polarized. The feedpoints of antenna **1** and antenna **2** as well as the feedpoints of antenna **3** and antenna **4** are separated by a distance $D1$, while the feedpoints of antenna **1** and antenna **3** as well as the feedpoints of antenna **2** and antenna **4** are separated by a distance $D2$.

In one embodiment, an RFID chip having more than two ports can be coupled to a shared antenna. Spatial diversity can be applied by designing the number of spatially separated

feedpoints on the antenna to equal the number of ports, where the RF terminal of each port is coupled to a different feedpoint. In one embodiment, a shared dipole antenna can be bent at approximately a right angle. Thus, the antenna has two arms, one on each side of the right angle. For spatial diversity to be applied effectively, there should be at least two distinct feedpoints on each arm of the antenna. In this configuration, the antenna can receive power from two different field orientations.

FIG. 4F shows a sixth example of spatial diversity 450 using one two-port RFID chip 452. The two antennas 412, 414 are co-polarized, and the feedpoints of the antennas 412, 414 are separated by a distance D1.

FIG. 4G shows an embodiment of a spatially diverse antenna configuration 460 for an RFID tag using a single two-port RFID chip 470 and a single shared linear dipole antenna 476 that is approximately one wavelength long. The two-port RFID chip 470 has two ports, and each port has two terminals. The first port has a first RF terminal 472 and a first ground terminal 473, and the second port has a second RF terminal 474 and a second ground terminal 475. The first and second ground terminals 473, 475 are both connected by conductive traces to approximately the midpoint 478 of the shared dipole antenna 476. The first RF terminal 472 is connected by a conductive trace to a feedpoint 477 on the dipole antenna 476 approximately one-quarter wavelength from the left end of the dipole antenna 476. The second RF terminal 474 is connected by a conductive trace to a feedpoint 479 on the dipole antenna 476 approximately one-quarter wavelength from the right end of the dipole antenna 476. Thus, the distance between the feedpoints 477, 479 is approximately one half wavelength. For an RF frequency of 900 MHz, the wavelength is approximately one third of a meter. The trace width can vary between approximately 1 mm and 10 mm, and the details on how the trace is bent or connected can also vary.

In the antenna configuration 460, the current distribution in the antenna 476 approximates a sine wave having a period of approximately one wavelength. The two ground terminals 473, 475 of the RFID chip 470 are coupled to the dipole antenna 476 at approximately the midpoint 478 because the current at or near the midpoint 478 is zero or close to zero. The two RF terminals 472, 474 of the RFID chip 470 are coupled to the feedpoints 477, 479 of the dipole antenna 476 because the current at the points located approximately one-quarter wavelength from each end of the dipole antenna 476 is a maximum.

Because the two ports of the RFID chip 470 are both coupled to one shared linear dipole antenna 476 at two separate feedpoints 477, 479, spatial diversity is advantageously achieved. The antenna configuration 460 will be less sensitive to the peaks and nulls of the RF signal due to multipath fading and also less sensitive to “hot” or “cold” spot locations on boxes or pallets. And significantly, the area occupied by the shared dipole antenna 476 is approximately equal to the area occupied by a single dipole antenna coupled to only one port of a two-port RFID chip 470.

FIG. 4H shows an example of a spatially diverse antenna configuration 4100 for an RFID tag that illustrates that an arbitrary shared antenna 4150 may be used; the shared antenna need not be a dipole antenna. RFID chip 4110 has two ports, and each port has two terminals. The ground terminals 4140 of the two ports are connected together to a common ground. The RF terminal of one of the ports is coupled to a first feedpoint 4120 on the shared antenna 4150, and the RF terminal of the other port is connected by a conductive trace to a second feedpoint 4130 on the shared antenna 4150. The

feedpoints 4120, 4130 are separated by a distance D. The distance D may range from zero to one half wavelength.

FIG. 4I shows another example of a spatially diverse antenna configuration 4200 for an RFID tag with shared antenna 4250. RFID chip 4210 has two ports, and each port has two terminals. The ground terminals 4240 of the two ports are connected together to a common ground. The RF terminal of one of the ports is coupled to a first feedpoint 4220 on the shared antenna 4250, and the RF terminal of the other port is connected by a conductive trace to a second feedpoint 4230 on the shared antenna 4250. The feedpoints 4220, 4230 are separated by a distance D. The total length of the shared antenna 4250 is approximately one half wavelength, the portion of the shared antenna to the left of the RFID chip 4210 is approximately one-quarter wavelength, and the distance D between the feedpoints 4220, 4230 may range from zero to one-quarter wavelength. A prototype based upon configuration 4200 is shown in FIG. 6, where the distance D is approximately one-twelfth of a wavelength.

FIGS. 4J and 4K show examples of spatial diversity using three-dimensional antenna configurations formed on a sphere as represented on paper. FIG. 4J shows an example of spatial diversity 480 using two two-port RFID chips 481, 482 with a three-dimensional antenna configuration. There are three orthogonally curved dipole antennas 483, 484, 485; antennas 483, 484 are coupled to RFID chip 481, and antennas 483, 485 are coupled to RFID chip 482. The curved dipole antenna 483 is shared and coupled to both RFID chip 481 and 482. The RFID chips 481, 482 are physically separated by a distance D so that the feedpoints of the shared antenna 483 is separated by a distance D.

FIG. 4K shows an example of spatial diversity 490 using three two-port RFID chips 491, 492, 493 with a three-dimensional antenna configuration. Three mutually orthogonal loop antennas 494, 495, 496 are shared and coupled to the three RFID chips 491, 492, 493. The RFID chips 491, 492, 493 are each located a distance D from the other RFID chips. Loop 494 is coupled to RFID chips 491, 492; loop 495 is coupled to RFID chips 492, 493; and loop 496 is coupled to RFID chips 491, 493. Thus, the feedpoints of the shared antennas are separated by a distance D.

Examples 480 and 490 are considered omni-directional antennas because an RFID tag having one of these antenna configurations will receive and be powered-up from RF signals transmitted by an RFID reader from any direction with any polarization. However, because the antenna configurations are three-dimensional, an RFID tag having an omni-directional antenna 480, 490 would ideally be attached to a spherical package. Suitable dimensions for the radius of the spherical package would be on the order of $\lambda/(2\pi)$, where λ is the wavelength of the RF signal. No protocols on the RFID chip need to be changed to implement the invention. Only software used by an RFID reader must be modified to recognize that RFID chips 481, 482 are part of a single tag 480 and a single object rather than identifying two different RFID tagged objects. Similar modifications are also needed for the tag example 490.

It should be noted that a shared antenna does not necessarily have to take the form of a dipole antenna. The shared antenna may be a loop antenna, a slot antenna, or a combination of dipole, loop, and/or slot antennas with variations such as folding or meandering. Thus, a shared antenna is not limited to any particular configuration.

Spatially separated antenna feedpoints may also enhance an RFID tag's bandwidth because the separate antenna feedpoints each experience different impedances. For example, the upper graph 500 shown in FIG. 5 shows reactance curves

as a function of frequency for a first antenna feedpoint **510**, a second antenna feedpoint **520**, and an RFID integrated circuit chip **530**. Impedance matching occurs at the frequency that the RFID chip's reactance curve **530** crosses the reactance curve for each of the antenna feedpoints **510**, **520**. Because the reactance curves for the first and second antenna feedpoints **510**, **520** are not identical, the RFID chip is impedance matched to the feedpoints **510**, **520** at different frequencies. In particular, impedance matching between the RFID chip and the first antenna feedpoint occurs at the point on the curves labeled **532**, and impedance matching between the RFID chip and the second antenna feedpoint occurs at the point on the curves labeled **534**. The point **534** is at a higher frequency than the point **532**.

When the RFID chip's reactance curve is impedance matched to an antenna feedpoint's reactance curve, a tag resonance occurs. A tag resonance is identifiable by a local maximum in the read range of the RFID tag. This means that when the RFID reader transmits RF signals at the tag's resonant frequency, the RFID tag can be powered by the RFID reader's signal at a farther distance from the RFID reader than when the RFID reader transmits an RF signal at a frequency removed from the tag's resonant frequency.

Typically, as with the example **350** of a tag with one linearly polarized antenna coupled to one port at one feedpoint, only one resonant tag frequency exists. However, when spatial diversity is used with RFID tags, at least two or more separate antenna feedpoints are present, resulting in two or more tag resonances. The lower graph **540** shown in FIG. **5** shows an example read range curve **550** as a function of frequency corresponding to the example reactance curves in the upper graph **500** in FIG. **5**. The impedance matched point **532** in the upper graph **500** results in a tag resonance at point **542** in the lower graph **540**, while the impedance matched point **542** results in a tag resonance at point **544**.

Typically, the RFID tag's bandwidth is the difference between the two RFID reader transmission frequencies that result in read ranges of the RFID tag at half of the read range of the RFID tag at its resonant frequency. It will be apparent to a person skilled in the art that other definitions may also be used for determining a tag's bandwidth. When there are two resonant frequencies located sufficiently close together in frequency, the bandwidth **560** of the RFID tag is widened. Consequently, the RFID tag is responsive to a wider range of RFID reader transmission frequencies at a minimum read range distance. The minimum read range may depend on the particular requirements of an application.

Further, an RFID tag's bandwidth may be tailored by selecting the impedances of the feedpoints. Many methods may be used to change the impedance of the feedpoints, including but not limited to, varying the thickness of the conductive trace between the port of the RFID chip and the antenna feedpoint, adding meandering elements in the conductive trace between the port of the RFID chip and the antenna feedpoint, and changing the dielectric material on which the RFID tag is situated.

FIG. **6** shows a photograph of a prototype RFID tag **660** and a corresponding schematic **600** of its antenna configuration. The RFID tag **600** has one shared linear dipole antenna **610** coupled at two separate feedpoints **620**, **630** to a two-port RFID chip **640**. The feedpoints **620**, **630** are separated by a distance **D** using a conducting trace **650** parallel to the shared dipole antenna **610**. The distance **D** is 25 mm, or approximately one-twelfth of a wavelength. In the photograph **660**, the conducting trace **650** is thinner than the width of the antenna **610**.

The prototype's performance was measured, and the read range of the RFID tag **660** as a function of frequency is shown in graph **700** in FIG. **7**. Curve **720** shows the read range for the RFID tag **660** when the antenna **610** was driven only at feedpoint **620**. Curve **730** shows the read range for the same RFID tag **660** when the antenna was **610** driven only at feedpoint **630**. For both curves, the antenna was driven with the same amount of incident RF power. The performance of the antenna is similar in both situations, and the shifted tag resonance is visible. The tag resonance is at a different frequency for curve **730** than for curve **720**, indicating that the impedances of the antennas at the feedpoints **620**, **630** are different.

Curve **710** shows the read range performance for the RFID tag **660** when the antenna is driven at the two feedpoints **620**, **630**. The same amount of RF power used to drive the individual feedpoints resulting in the curves **720** and **730** is split between driving the feedpoints **620**, **630**. The result of driving the antenna at two spatially separated feedpoints **620**, **630** is an approximately 25% increase in read range distance as well as broadening of the tag's bandwidth. Thus, using an RFID tag having a single two-port RFID chip with a single linear dipole antenna and separated feedpoints established through the use of an additional conductive trace significantly improves the performance of the RFID tag compared to using a standard single dipole tag similar to the example RFID tag **350** with a minimal increase in cost.

The words "herein," "above," "below," and words of similar import, when used in this application, shall refer to this application as a whole and not to any particular portions of this application. Where the context permits, words in the above Detailed Description using the singular or plural number may also include the plural or singular number respectively. The word "or," in reference to a list of two or more items, covers all of the following interpretations of the word: any of the items in the list, all of the items in the list, and any combination of the items in the list.

The above detailed description of embodiments of the invention is not intended to be exhaustive or to limit the invention to the precise form disclosed above. While specific embodiments of, and examples for, the invention are described above for illustrative purposes, various equivalent modifications are possible within the scope of the invention, as those skilled in the relevant art will recognize. For example, while an RFID reader for reading RFID tags are mentioned, any reading apparatus for reading devices emitting radio-frequency signals may be used under the principles disclosed herein. Further any specific numbers noted herein are only examples: alternative implementations may employ differing values or ranges.

The teachings of the invention provided herein can be applied to other systems, not necessarily the system described above. The elements and acts of the various embodiments described above can be combined to provide further embodiments.

While the above description describes certain embodiments of the invention, and describes the best mode contemplated, no matter how detailed the above appears in text, the invention can be practiced in many ways. Details of the system may vary considerably in its implementation details, while still being encompassed by the invention disclosed herein. As noted above, particular terminology used when describing certain features or aspects of the invention should not be taken to imply that the terminology is being redefined herein to be restricted to any specific characteristics, features, or aspects of the invention with which that terminology is associated. In general, the terms used in the following claims

should not be construed to limit the invention to the specific embodiments disclosed in the specification, unless the above Detailed Description section explicitly defines such terms. Accordingly, the actual scope of the invention encompasses not only the disclosed embodiments, but also all equivalent ways of practicing or implementing the invention under the claims.

We claim:

1. An RFID tag comprising:
 - a dual-port RFID chip having a first port and a second port, wherein the first port has a first RF terminal and a first ground terminal, and the second port has a second RF terminal and a second ground terminal; and
 - a shared antenna having a first feedpoint and a second feedpoint,
 wherein the first RF terminal couples to the first feedpoint located at a first point on the shared antenna, the second RF terminal couples to the second feedpoint at a second point a distance away from the first feedpoint on the shared antenna, and the first and second ground terminals couple to approximately a center point on the shared antenna,
 - wherein a length of the shared antenna is approximately one wavelength, the first point is approximately one-quarter wavelength from a first end of the shared antenna, and the second point is approximately one-quarter wavelength from a second end of the shared antenna, and
 - wherein the dual-port RFID chip and the shared antenna are configured for spatial antenna diversity and configured to reduce sensitivity to multi-path fading in response to a received wireless RFID signal.
2. The RFID tag of claim 1 wherein the shared antenna includes a dipole antenna having first and second portions coupled respectively to the first and second ports, and wherein first and second portions of the dipole antenna are coplanar and co-polarized.
3. The RFID tag of claim 1 wherein the shared antenna is selected from a group consisting of a dipole antenna, a loop antenna, a slot antenna, and a combination of dipole, loop, and/or slot antennas.
4. The RFID tag of claim 1 wherein the shared antenna is folded.
5. The RFID tag of claim 1 wherein the shared antenna includes meander elements or stub elements.
6. An RFID tag comprising:
 - at least one RFID chip having multiple ports, wherein each port has an RF terminal and a ground terminal; and
 - at least one shared antenna having multiple feedpoints, wherein a total number of RF terminals equals a number of feedpoints on the shared antenna, each RF terminal is coupled to a different feedpoint, and each feedpoint is located at a different point on the antenna.
7. The RFID tag of claim 6 wherein the shared antenna is bent at substantially a right angle, having one arm on each side of the bend, and further wherein at least two feedpoints are located on each arm of the antenna.
8. The RFID tag of claim 6 wherein all the ground terminals are coupled to one point on the shared antenna.
9. The RFID tag of claim 6 wherein the shared antenna is selected from a group consisting of a dipole antenna, a loop antenna, a slot antenna, and a combination of dipole, loop, and/or slot antennas.
10. The RFID tag of claim 6 wherein the shared antenna is folded.
11. The RFID tag of claim 6 wherein the shared antenna includes meander elements or stub elements.

12. An RFID tag comprising:
 - an RFID chip having multiple ports, wherein each port has an RF terminal and a ground terminal; and
 - multiple antennas each having at least one feedpoint, wherein each feedpoint is at a different location from all other feedpoints, and further wherein each RF terminal is coupled to one of the feedpoints.
13. The RFID tag of claim 12 wherein the multiple antennas include cross-polarized antennas.
14. The RFID tag of claim 12 wherein the multiple antennas are selected from a group consisting of a dipole antenna, a loop antenna, a slot antenna, and a combination of dipole, loop, and/or slot antennas.
15. The RFID tag of claim 12 wherein the multiple antennas are folded.
16. The RFID tag of claim 12 wherein the multiple antennas include meander elements or stub elements.
17. An RFID tag comprising:
 - multiple RFID chips, wherein each RFID chip has multiple ports, and each port has an RF antenna terminal and a ground terminal; and
 - an antenna portion, wherein the antenna portion is either:
 - multiple antennas each having at least one feedpoint, wherein each feedpoint is at a different location from all other feedpoints, and further wherein each RF terminal is coupled to one of the feedpoints, or
 - at least one shared antenna having at least two separated feedpoints, wherein at least two different RF terminals are coupled to the at least two separated feedpoints.
18. The RFID tag of claim 17 wherein the multiple RFID chips are arranged in a two-dimensional configuration.
19. The RFID tag of claim 17 wherein the multiple RFID chips are arranged in a three-dimensional configuration.
20. The RFID tag of claim 17 wherein the multiple antennas or the shared antenna are selected from a group consisting of a dipole antenna, a loop antenna, a slot antenna, and a combination of dipole, loop, and/or slot antennas.
21. The RFID tag of claim 17 wherein the multiple antennas or the shared antenna is folded.
22. The RFID tag of claim 17 wherein the multiple antennas or the shared antenna include meander elements or stub elements.
23. An RFID tag comprising:
 - an RFID chip having a frequency-dependent chip reactance; and
 - a shared antenna having a plurality of feedpoints, wherein each feedpoint has a frequency-dependent feedpoint reactance, and the frequency-dependent chip reactance is substantially matched to each of the frequency-dependent feedpoint reactances at least one frequency.
24. The RFID tag of claim 23, wherein the shared antenna is selected from a group consisting of a dipole antenna, a loop antenna, a slot antenna, and a combination of dipole, loop, and/or slot antennas.
25. The RFID tag of claim 23, wherein the shared antenna is folded.
26. The RFID tag of claim 23, wherein the shared antenna includes meander elements or stub elements.
27. An RFID tag comprising:
 - a dual-port RFID chip having a first port and a second port, wherein the first port has a first RF terminal and a first ground terminal, and the second port has a second RF terminal and a second ground terminal; and
 - a shared antenna having a first feedpoint and a second feedpoint,

11

wherein the first RF terminal couples to the first feedpoint located at a first point on the shared antenna, the second RF terminal couples to the second feedpoint at a second point a distance away from the first feedpoint on the shared antenna, and the first and second ground terminals couple to approximately a center point on the shared antenna.

28. The RFID tag of claim **27**, wherein the shared antenna includes a dipole antenna having first and second portions coupled respectively to the first and second ports, and wherein first and second portions of the dipole antenna are coplanar and co-polarized.

12

29. The RFID tag of claim **27**, wherein the shared antenna is selected from a group consisting of a dipole antenna, a loop antenna, a slot antenna, and a combination of dipole, loop, and/or slot antennas.

30. The RFID tag of claim **27**, wherein the shared antenna is folded.

31. The RFID tag of claim **27**, wherein the shared antenna includes meander elements or stub elements.

* * * * *