

(19)



(11)

**EP 3 425 812 B1**

(12)

**EUROPEAN PATENT SPECIFICATION**

(45) Date of publication and mention of the grant of the patent:  
**19.04.2023 Bulletin 2023/16**

(51) International Patent Classification (IPC):  
**H04B 1/401** <sup>(2015.01)</sup>      **H04B 1/00** <sup>(2006.01)</sup>  
**G06K 7/00** <sup>(2006.01)</sup>      **H04B 1/48** <sup>(2006.01)</sup>  
**H04B 1/58** <sup>(2006.01)</sup>      **G06K 7/10** <sup>(2006.01)</sup>

(21) Application number: **18182023.4**

(52) Cooperative Patent Classification (CPC):  
**G06K 7/0004; G06K 7/10386; H04B 1/006;**  
**H04B 1/0067; H04B 1/401; G06K 7/10009;**  
**H04B 1/48; H04B 1/58**

(22) Date of filing: **05.07.2018**

**(54) SYSTEMS AND METHODS FOR A RECONFIGURABLE RADIO FRONT-END**

SYSTEME UND VERFAHREN FÜR EIN REKONFIGURIERBARES FUNK-FRONTEND

SYSTÈMES ET PROCÉDÉS POUR CIRCUIT FRONTAL RADIO RECONFIGURABLE

(84) Designated Contracting States:  
**AL AT BE BG CH CY CZ DE DK EE ES FI FR GB**  
**GR HR HU IE IS IT LI LT LU LV MC MK MT NL NO**  
**PL PT RO RS SE SI SK SM TR**

- **KELLY, Stephen J.**  
Morris Plains, New Jersey 07950 (US)
- **ARUL, Anthony B.**  
Morris Plains, New Jersey 07950 (US)

(30) Priority: **07.07.2017 US 201715644016**

(74) Representative: **Haseltine Lake Kempner LLP**  
**Cheapside House**  
**138 Cheapside**  
**London EC2V 6BJ (GB)**

(43) Date of publication of application:  
**09.01.2019 Bulletin 2019/02**

(73) Proprietor: **Intermec, Inc.**  
**Lynwood, WA 98087 (US)**

(56) References cited:  
**US-A1- 2006 238 306 US-A1- 2010 137 024**

(72) Inventors:  
 • **NIKITIN, Pavel**  
**Morris Plains, New Jersey 07950 (US)**

**EP 3 425 812 B1**

Note: Within nine months of the publication of the mention of the grant of the European patent in the European Patent Bulletin, any person may give notice to the European Patent Office of opposition to that patent, in accordance with the Implementing Regulations. Notice of opposition shall not be deemed to have been filed until the opposition fee has been paid. (Art. 99(1) European Patent Convention).

**Description**BACKGROUND

**[0001]** Conventional radio devices include a non-configurable front-end. In particular, these devices have a fixed front-end topology to operate at a specific frequency band. For example, 802.11 abgn radios, operating at 2.4 GHz and 5.8 GHz bands have time multiplexing performed using a transmit/receive (Tx/Rx) switch, while UHF RFID radios operating at the 915 MHz band (and other ISM UHF bands) have a radar-like front end where transmission and reception are performed simultaneously at the same frequency. In these conventional devices, UHF RFID (869/915 MHz bands) and WiFi (2.4/5.8 GHz abnd) standards require two very different radio front-end architectures that are very difficult to integrate together in a handheld device, including requiring different Tx/Rx chipsets, different RF front ends, and different antennas.

**[0002]** US 2010/137024 A1 discloses a transceiver circuit including an input to receive an RF mode control signal, multiple ports, and path circuitry disposed between the multiple ports. The path circuitry can be configured to create different low impedance conductive paths between the multiple ports depending on a state of the RF mode control signal.

**[0003]** US 2006/238306 A1 discloses an RFID reader for communicating with an RFID tag and with a remote RF transceiver, the RFID reader comprising: a single transceiver for communicating with RFID tags and with a remote RF transceiver; and a single antenna coupled to the transceiver; wherein, in a first mode, the transceiver communicates with the RFID tags via the antenna on a first frequency; and, in a second mode, the transceiver communicates with the remote RF transceiver via the same antenna on the first frequency or a second frequency.

SUMMARY

**[0004]** To overcome these and other challenges, aspects of broad inventive principles are disclosed herein.

**[0005]** The invention is defined in the independent claims, to which reference should now be made. Advantageous embodiments are set out in the dependent claims.

BRIEF DESCRIPTION OF THE DRAWINGS**[0006]**

Figure 1 is a block diagram illustrating a system according to one embodiment.

Figures 2A, 2B and 2C schematically illustrate an RFID apparatus according to one embodiment.

Figure 3 is a block diagram of a reconfigurable front-end according to one embodiment.

Figure 4 depicts a scanning and communication operation according to one embodiment.

Figure 5 is a flowchart of a method according to one or more embodiments.

10 DETAILED DESCRIPTION

**[0007]** The exemplary embodiments described herein provide detail for illustrative purposes and are subject to many variations in structure and design. It should be appreciated, however, that the embodiments are not limited to a particularly disclosed embodiment shown or described. It is understood that various omissions and substitutions of equivalents are contemplated without departing from the scope of the claims.

**[0008]** Also, it is to be understood that the phraseology and terminology used herein is for the purpose of description and should not be regarded as limiting. The terms "a," "an," and "the" herein do not denote a limitation of quantity, but rather denote the presence of at least one of the referenced object. It will be further understood that the terms "comprises" and/or "comprising," when used in this specification, specify the presence of stated features, integers, steps, operations, elements, and/or components, but do not preclude the presence or addition of one or more other features, integers, steps, operations, elements, components, and/or groups thereof. Like numerals represent like parts in the Figures.

**[0009]** Various embodiments include systems and methods for a reconfigurable radio front-end, such as a reconfigurable front-end for a portable communication device or a radio-frequency identification (RFID) reader. More particularly, in some embodiments, the front-end is configured to operate in the WiFi standard, 802.11 ah, that will operate in the same unlicensed sub-1 GHz band, where all UHF RFID systems already operate (e.g. 869 MHz band in Europe, 915 MHz band in the US, etc.). In various embodiments, a transmitter and receiver hardware (chipset) for 802.11ah is configured to generate and receive UHF RFID signals as well (AM modulated reader-to-tag and IQ reception and decoding of BPSK modulated signals from tag). For example, in various embodiments, a reconfigurable topology front-end allows WiFi 802.11ah (915 MHz) and UHF RFID (915 MHz) systems to share a same common radio (Tx/Rx chipset) and a same common antenna. Thus, in some embodiments, the transmitter and receiver hardware (Chipset) for 802.11ah is made capable of generating and receiving UHF RFID signals (e.g., AM modulated reader-to-tag IQ reception and decoding of BPSK modulated signals from an RFID tag).

**[0010]** In various embodiments, the reconfigurable front-end can be driven by a radio (e.g., RFID reader with a radio transceiver) and communicate in different fre-

quency bands using a common antenna. It should be understood that while the reconfigurable front-end may be described in connection with handheld or portable computing devices for a particular application, the reconfigurable front-end may be used with different devices, and in many different applications. It should be noted that the reconfigurable front-end and various components are referred to herein for ease of illustration. However, it should be understood that the system and various components may be configured as a reconfigurable front-end for any type of radio transceiver system, which may include an RFID scanning system.

**[0011]** In one embodiment, a system 100 (e.g., a radio) with a reconfigurable front-end according to various embodiments may be implemented as shown in Figure 1. The system 100 may be embodied as or form part of a handheld RFID scanner. For example, the system 100 may be embodied or form part of a mobile computing device, such as an Intermec mobile computer available from Honeywell Scanning and Mobility.

**[0012]** The system 100 may comprise a transmitter 102 and a receiver 106, both connected to an antenna 108 (e.g., a single common antenna) via a reconfigurable front-end 114. The transmitter 102 and receiver 106 (and associated components) may be provided, for example, within a housing of the system (e.g., within a housing of an RFID reader). The reconfigurable front-end 114 allows for communication in different frequency bands as described herein.

**[0013]** It should be noted that the antenna 108 may include various antenna elements and/or may take different configurations as would be used in antenna technology, such a particular to RFID antenna technology or WiFi antenna technology, or both. For example, the antenna elements may be arranged or aligned to form different sized and shaped arrays as desired or needed, such as based on RFID tags to be scanned or other communications to be performed, such as communicating WiFi data.

**[0014]** The transmitter 102 and receiver 106 are coupled through the reconfigurable front-end 114 to the antenna 108 to provide transmission and reception selectively at different operating frequency bands. For example, transmission and reception may be provided for WiFi or RFID communications. When providing RFID communication (e.g., transmitting and receiving RFID signals using the antenna 108), the system 100 is operable to scan a region of interest 134 to acquire RFID tag information. Thus, the antenna 108 in this configuration is operable to provide RFID communication. In other embodiments, as described herein, other types of communication may be provided by switching the front-end communication configuration of the system 100 using the reconfigurable front-end 114, such as to perform WiFi communication, such as to communicate acquired RFID information through a network. In some embodiments, when operating using a WiFi communication front-end, RFID over WiFi communication may be provided.

**[0015]** In the illustrated embodiment of Figure 1, the system 100 may also comprise a controller 110 coupled to the transmitter 102 and receiver 106 to generate signals, such as both RFID read signals and control signals for use in RFID communications or WiFi control or data signals for use in WiFi communications, which may be communicated via control line 104. For example, the control line 104 (which may be one or more transmission lines) transmit switch control signals to one or more components of the reconfigurable front-end 114. It should be noted that any type of communicative or operative coupling may be used, such as any type of wireless or wired communication.

**[0016]** The controller 110 is also coupled to the reconfigurable front-end 114. The controller 110 is configured to select a particular front-end communication configuration by selectively activating one of a plurality of front-end communication configurations as discussed in more detail herein, and/or to control one or more components during communication.

**[0017]** Thus, the controller 110 is configured to control the operation of the transmitter 102 and receiver 106, such as to control the transmissions and the reception by the antenna 108, as well as the configuration of front-end by controlling the selection of the front-end topology of the reconfigurable front-end 114. In one embodiment, the controller 110 is a transmit and receive controller configured to control signals, such as the radio-frequency (RF) pulses sent to the antenna 108 the communication of signals received by the antenna 108, as well as control signals sent to the reconfigurable front-end 114 to change the front-end configuration of the reconfigurable front-end 114, which changes the front-end communication configuration of the system 100.

**[0018]** The system 100 may further comprise a processor 112 coupled to the controller 110. As described in more detail herein, the processor 112 can control the operation of the controller 110 to transmit and receive as desired or needed, including to change the front-end configuration of the system 100, which may be dynamically reconfigured by selecting a front-end communication topology of the reconfigurable front-end 114.

**[0019]** In an RFID communication mode, the processor 112 is also configured in various embodiments to process received signal information to determine the location and/or acquire information for one or more RFID tags 132a, 132b coupled to items 130a, 130b. For example, the region of interest 134 may be a portion of a storage facility having a large number of RFID tagged objects or items and the RFID tag 132 may be affixed directly to the item 130 or a packaging of the item using techniques in the art. The processor 114, in this RFID communication mode of operation, is configured to receive tag response and/or read information using the antenna 108.

**[0020]** As another example, in a WiFi communication mode, the processor 112 is also configured in various embodiments to process received signal information, including WiFi data, such as to decode or demultiplex re-

ceived WiFi data packets. It should be noted that RFID and WiFi communications are two types of communication that may be provided by selectively controlling the reconfigurable front-end 114. However, other communication methods and protocols may be used based on the configuration of the reconfigurable front-end 114.

**[0021]** A memory 120, which may be any type of electronic storage device, can be coupled to the processor 112 (or form part of the processor 112). The processor 112 may access the memory 120 to obtain stored information 122 such as control information for use in selectively changing the configuration of the reconfigurable front-end 114.

**[0022]** The system 100 may also comprise a display 124 and a user input device 128 coupled to the processor 112 to allow user interaction with the system 100. For example, the display 124 can allow selecting a particular front-end configuration for the reconfigurable front-end 114 based on the type of communication to be performed, such as an RFID scan or WiFi data connection. It should be noted that in some embodiments, the display 124 and user input device 128 may be integrated, such as in a touchscreen display device.

**[0023]** While Figure 1 illustrates a particular connection arrangement of the various components, a skilled artisan would appreciate the fact that other connection arrangements may be made that are within the scope of this disclosure. Additionally, the various components may be housed within the same or different physical units and the separation of components within Figure 1 is merely for illustration. The system 100 may also comprise one or more communication subsystems to allow communication with external devices, such as networks, printers, etc. Thus, additional components may form part of or communicate with the system 100.

**[0024]** In some embodiments, the system 100 may be embodied as part of a RFID apparatus 200 is shown in Figures 2A (front panel view), 2B (oblique panel view) and 2C (bottom panel view). The RFID apparatus 200 (e.g., RFID reader) can comprise a housing 202 within which other components of RFID apparatus 200 can be disposed. An LCD screen display with touch screen sensor 206 can be disposed on a front panel 208. Also disposed on the front panel 208 can be an operation LED 204, a scan LED 210, and keyboard 212 including a scan key 214 and navigation keys 216. An imaging window 218 can be disposed on the top panel of the housing 202. Disposed on the side panel (best viewed in Figure 2B) can be an infrared communication port 220, an access door to a secure digital (SD) memory interface 222, an audio jack 224, and a hand strap 226. Disposed on the bottom panel (best viewed in Figure 1C) can be a multi-pin mechanical connector 228 and a hand strap clip 230.

**[0025]** Also disposed on the bottom panel (or alternatively on the top panel) can be an RFID antenna housing and an RFID read device (which may include the transmitter 102 and receiver 106 shown in Figure 1) within the housing 202. In the illustrated embodiment, a con-

nection port 232 is provided for connection to an external device.

**[0026]** While Figures 1A-1C illustrate one embodiment of a handheld housing, a skilled artisan would appreciate that other types and form factors of terminal housings are within the scope of this disclosure.

**[0027]** In one embodiment, as illustrated in Figure 3, a reconfigurable front-end 300 is provided and switchable between front end topologies, which in the illustrated embodiment is between WiFi and RFID communication topologies. The reconfigurable front-end 300 may be configured as, embodied as or form part of the reconfigurable front-end 114. The reconfigurable front-end 300 includes a switch 302 that is configured to switch between the WiFi and RFID communication topologies (also referred to as a WiFi/RFID switch) by switching between a WiFi communication path 304 and an RFID communication path 306 (the different sub-paths for each of these communication paths are identified by reference numerals 304 and 306). For example, by switching between the paths 304 and 306 using the switch 302, communication components corresponding to WiFi communication or RFID communication, respectively, are selected.

**[0028]** In the embodiment illustrated in Figure 3, the switch 302 is illustrated as switched to a WiFi communication mode of operation, such that transmission and reception is provided through a WiFi front end topology. In the illustrated embodiment, a transmitter 310 and a receiver 312, which may be configured as, embodied as or form part of the transmitter 102 and receiver 106 (both shown in Figure 1), are connected to an input of the switch 302 via a power amplifier 314. The power amplifier is configured to increase the power level of the signals to the switch 302, which may include WiFi or RFID signals (e.g., an RFID read signal) to be transmitted from the antenna 108 (shown in Figure 1).

**[0029]** The switch 302 may be any type of switch, such as a semiconductor switch with a digital interface, which may be an RF-type switch. It should be noted that although the switch is shown as a 3 to 6 switch, different configurations of switches (e.g., 1 to 2 or 2 to 4), including multiple switches may be provided. The switch 302 is controlled using switching techniques in the semiconductor or RF switching technology, such as using control signals generated by the controller 110 (shown in Figure 1). By controlling the switch 302 using the control commands, one or more switching elements 308 (or switching components) are switchable to provide different types of communication by connecting to different front-end topologies. As described herein, in the illustrated embodiment, the switching by the switch 302 selects the WiFi communication or RFID communication. However, it should be appreciated that the switching may be controlled such that the two types of communication are separately provided or simultaneously provided.

**[0030]** In one embodiment, the switch 302 is a pseudomorphic high-electron-mobility transistor (pHEMT) gallium arsenide (GaAs) switch, such as an AS193-73LF

RF switch (available from Skyworks). In this embodiment, the controller 110 outputs signals to switch the switch 302 (e.g., the RF switch may be controlled by signals from RFID IC GPIO (general-purpose input/output) pins of the EM4325 Gen 2 IC). However, it should be appreciated that any type of controllable switching element may be used. For example, although the switch 302 is illustrated as a series of single triple pole dual throw (TP-DT) switching elements, different switches or switching arrangements may be used. Thus, reconfigurable communication paths may be provided.

**[0031]** In operation, in the illustrated embodiment, the switch 302 is configured to control switching between WiFi and RFID communications, namely between a WiFi front-end section and an RFID front-end section. In the illustrated embodiment, the WiFi front-end section includes a switch 314 configured to operate as a WiFi Tx/Rx switch for a WiFi radio topology front-end section. The switch 314 switches between transmission and reception for the WiFi communication paths 304. It should be noted that the switch may be a multiple-input and multiple-output (MIMO) switch that is controllable using signals from the controller 110. In the illustrated embodiment, control lines 322 and 324 transmit control signals for controlling switching of the switch 302 and the switch 314. For example, the control lines 322 and 324 may be configured as, embodied as or form part of the control line 104 (shown in Figure 1) that transmit switch control signals from the controller 110 (shown in Figure 1).

**[0032]** The reconfigurable front-end 300 also includes a filter 316 connected at an output end of the reconfigurable front-end 300. In the illustrated embodiment, the filter 316 is a band-pass filter that is configured in various embodiments to filter out signal harmonics. For example, the filter 316 is connected to an antenna 318, which may be configured as, embodied as or form part of the antenna 108 (illustrated in Figure 1). In operation, the filter 316 filters signals before transmission and after reception. It should be noted that the filter 316 is configured to operate both during WiFi communications and RFID communications. In particular, the filter 316 is connected to a switching element 308c of the switch 302 that switches between communication paths for WiFi communications and RFID communications, respectively.

**[0033]** The switch 302 is switchable to an RFID communication mode by switching all of the switching elements 308 from the position (poles) illustrated in Figure 3 to the other position (pole). In the illustrated embodiment, the RFID front-end section includes an isolator 320 configured as a circulator to isolate the transmission and reception paths for RFID communications. In particular, the transmission and return reception paths are isolated such that signals that are transmitted cannot return through the same path. Thus, the transmit signal is prevented from passing to the receive communication path. Similar to the WiFi communication mode of operation, the RFID front-end section is also connected to the filter 316.

**[0034]** Thus, using the reconfigurable front-end 300, the same radio and antenna may be used for different types of communication, illustrated as WiFi and RFID communications. In various embodiments, the RFID topology, having communication at a lower data rate than the WiFi topology, is essentially "piggybacked" onto the WiFi topology. In some embodiments, the WiFi and RFID communications are provided using a 915 MHz frequency. Thus, using reconfigurable communication paths and selectable front-end topologies, the same radio may be used for different communications that otherwise would have to be provided using different radios. For example, the various embodiments can be operated in different modes for use in different frequency bands. In some embodiments, the reconfigurable front-end has a reconfigurable architecture allowing WiFi 802.11ah and UHF RFID to share a common Tx/Rx radio chipset and a common antenna.

**[0035]** It should be appreciated that the herein disclosed subject matter can be generalized for different types of WiFi and Bluetooth architectures and result in specific front end embodiments, such as for any of the following cases:

1. When WiFi uses MIMO.
2. When RFID uses bistatic and multistatic configurations.
3. When both WiFi and RFID use the same frequency band that is different from 915 MHz (for example, 2.4 GHz).

**[0036]** With the herein disclosed configurations, the reconfigurable front-end does not require the use of additional components or separate radios. It should be noted that the various embodiments may be used in different applications with reconfigurable front-end controlled using appropriate commands or signals for the particular operating environment.

**[0037]** In various embodiments, the RFID apparatus 200 is moved in one or more directions to scan the region of interest 134 (shown in Figure 1) to perform a read scan for RFID tags 132. For example, as illustrated in Figure 4, a field of view 500 of the RFID apparatus 200 is scanned within the region of interest 134 to locate a particular item 130 using a reconfigurable antenna polarization or radiation pattern as described herein. In the illustrated embodiment, the RFID apparatus 200 is also switchable as described herein to provide WiFi communication 502, such as to communicate wirelessly with a network.

**[0038]** Thus, various embodiments provide a reconfigurable front-end arrangement that can be easily reconfigured with control signals to switch between an RFID communication mode and a WiFi communication mode. It should be noted that while the various embodiments are described in connection with particular operating characteristics, the various embodiments are not limited to the specific operating environment. Thus, one or more

embodiments may be used in connection with different devices or in different applications.

**[0039]** A method 600 for providing a reconfigurable front-end is illustrated in Figure 5. It should be appreciated that the method 600 may be implemented by one or more the embodiments disclosed herein, which may be combined or modified as desired or needed. Additionally, the steps in the method 600 may be modified, changed in order, performed differently, performed sequentially, concurrently or simultaneously, or otherwise modified as desired or needed.

**[0040]** The method 600 includes configuring a switching for switching between different front-end communication topologies. For example, as described herein, a switch is configured to switch between communication components that allow communication using WiFi communication or RFID communication.

**[0041]** Once the switch is set to a desired state at 604 (e.g., transmitting a control signal to select a WiFi front-end topology or an RFID front-end topology), the controller can communicate using the selected topology at 606. For example, in the RFID communication mode, communication with an RFID tag via the antenna may be provided. For example, the controller may send a control, read, interrogation, or other command signal or RFID signal via the antenna to communicate with an RFID tag. In response, the RFID tag may provide RFID data or other information. In the WiFi communication mode, wireless WiFi communication with, for example, a network may be provided.

**[0042]** Thus, various embodiments provide a switchable or reconfigurable front-end that can be implemented in a single radio using the same antenna.

**[0043]** It should be noted that one or more embodiments can comprise one or more microprocessors (which may be embodied as a processor) and a memory, coupled via a system bus. The microprocessor can be provided by a general purpose microprocessor or by a specialized microprocessor (e.g., an ASIC). In one embodiment, the system can comprise a single microprocessor which can be referred to as a central processing unit (CPU). In another embodiment, one or more configurations described herein can comprise two or more microprocessors, for example, a CPU providing some or most of the scanning functionality and a specialized microprocessor performing some specific functionality, such as to determine distance information and correlate that information with the acquired image information. A skilled artisan would appreciate the fact that other schemes of processing tasks distribution among two or more microprocessors are within the scope of this disclosure. The memory can comprise one or more types of memory, including but not limited to: random-access-memory (RAM), non-volatile RAM (NVRAM), etc.

**[0044]** It should be noted that, for example, the various embodiments can communicate between components using different standards and protocols. For example, the wireless communication can be configured to sup-

port, for example, but not limited to, the following protocols: at least one protocol of the IEEE 802.11/802.15/802.16 protocol family, at least one protocol of the HSPA/GSM/GPRS/EDGE protocol family, TDMA protocol, UMTS protocol, LTE protocol, and/or at least one protocol of the CDMA/1xEV-DO protocol family.

**[0045]** The flowcharts and block diagrams in the Figures illustrate the architecture, functionality, and operation of possible implementations of systems, methods and computer program products according to various embodiments of the present disclosure. In this regard, each block in the flowchart or block diagrams may represent a module, segment, or portion of code, which comprises one or more executable instructions for implementing the specified logical function(s). It should also be noted that, in some alternative implementations, the functions noted in the block may occur out of the order noted in the figures. For example, two blocks shown in succession may, in fact, be executed substantially concurrently, or the blocks may sometimes be executed in the reverse order, depending upon the functionality involved. It will also be noted that each block of the block diagrams and/or flowchart illustration, and combinations of blocks in the block diagrams and/or flowchart illustration, can be implemented by special purpose hardware-based systems which perform the specified functions or acts, or combinations of special purpose hardware and computer instructions.

**[0046]** The corresponding structures, materials, acts, and equivalents of any means or step plus function elements in the claims below are intended to include any structure, material, or act for performing the function in combination with other claimed elements as specifically claimed. The description of the present disclosure has been presented for purposes of illustration and description, but is not intended to be exhaustive or limited to embodiments in the form disclosed. Many modifications and variations will be apparent to those of ordinary skill in the art without departing from the scope and spirit of embodiments of the disclosure. The embodiments were chosen and described in order to best explain the principles of embodiments and practical application, and to enable others of ordinary skill in the art to understand embodiments with various modifications as are suited to the particular use contemplated.

**[0047]** Furthermore, as will be appreciated by one skilled in the art, aspects of the present disclosure may be embodied as a system, method, or computer program product. Accordingly, aspects of various embodiments may take the form of an entirely hardware embodiment, an entirely software embodiment (including firmware, resident software, microcode, etc.) or an embodiment combining software and hardware aspects that may all generally be referred to herein as a "circuit," "module", "system" or "sub-system." In addition, aspects of the present disclosure may take the form of a computer program product embodied in one or more computer readable medium(s) having computer readable program code

embodied thereon.

**[0048]** Any combination of one or more computer readable medium(s) may be utilized. The computer readable medium may be a computer readable signal medium or a computer readable storage medium. A computer readable storage medium may be, for example, but not limited to, an electronic, magnetic, optical, electromagnetic, infrared, or semiconductor system, apparatus, or device, or any suitable combination of the foregoing. More specific examples (a non-exhaustive list) of the computer readable storage medium include the following: an electrical connection having one or more wires, a portable computer diskette, a hard disk, a random access memory (RAM), a read-only memory (ROM), an erasable programmable read-only memory (EPROM or Flash memory), an optical fiber, a portable compact disc read-only memory (CD-ROM) or similar DVD-ROM and BD-ROM, an optical storage device, a magnetic storage device, or any suitable combination of the foregoing. In the context of this document, a computer readable storage medium may be any tangible medium that can contain, or store a program for use by or in connection with an instruction execution system, apparatus, or device.

**[0049]** A computer readable signal medium may include a propagated data signal with computer readable program code embodied therein, for example, in base-band or as part of a carrier wave. Such a propagated signal may take any of a variety of forms, including, but not limited to, electro-magnetic, optical, or any suitable combination thereof. A computer readable signal medium may be any computer readable medium that is not a computer readable storage medium and that can communicate, propagate, or transport a program for use by or in connection with an instruction execution system, apparatus, or device.

**[0050]** Program code embodied on a computer readable medium may be transmitted using any appropriate medium, including but not limited to wireless, wireline, optical fiber cable, RF, etc., or any suitable combination of the foregoing. Computer program code for carrying out operations for one or more embodiments may be written in any combination of one or more programming languages, including an object oriented programming language such as Java, Smalltalk, C++ or the like and conventional procedural programming languages, such as the "C" programming language or similar programming languages. The program code may execute entirely on the user's computer, partly on the user's computer, as a stand-alone software package, partly on the user's computer and partly on a remote computer or entirely on the remote computer or server. In the latter scenario, the remote computer may be connected to the user's computer through any type of network, including a local area network (LAN) or a wide area network (WAN), or the connection may be made to an external computer (for example, through the Internet using an Internet Service Provider).

**[0051]** At least some of the present disclosure is de-

scribed herein with reference to flowchart illustrations and/or block diagrams of methods, apparatus (systems) and computer program products according to embodiments described herein. It will be understood that each block of the flowchart illustrations and/or block diagrams, and combinations of blocks in the flowchart illustrations and/or block diagrams, can be implemented by computer program instructions. These computer program instructions may be provided to a processor of a general purpose computer, special purpose computer, or other programmable data processing apparatus to produce a machine, such that the instructions, which execute via the processor of the computer or other programmable data processing apparatus, create means for implementing the functions/acts specified in the flowchart and/or block diagram block or blocks.

**[0052]** These computer program instructions may also be stored in a computer readable medium that can direct a computer, other programmable data processing apparatus, or other devices to function in a particular manner, such that the instructions stored in the computer readable medium produce an article of manufacture including instructions which implement the function/act specified in the flowchart and/or block diagram block or blocks.

**[0053]** The computer program instructions may also be loaded onto a computer, other programmable data processing apparatus, or other devices to cause a series of operational steps to be performed on the computer, other programmable apparatus or other devices to produce a computer implemented process such that the instructions which execute on the computer or other programmable apparatus provide processes for implementing the functions/acts specified in the flowchart and/or block diagram block or blocks and when implemented in one or more embodiments, results in a transforming or converting a general purpose computer/processor/hardware to a specialized computer/processor/hardware that improves the technological art.

**[0054]** The foregoing descriptions of specific embodiments have been presented for purposes of illustration and description. They are not intended to be exhaustive or to limit the embodiments to the precise forms disclosed, and obviously many modifications and variations are possible in light of the above teaching within the scope of the invention as defined by the appended claims. The embodiments were chosen and described in order to best explain principles and practical applications thereof, and to thereby enable others skilled in the art to best utilize the various embodiments with various modifications as are suited to the particular use contemplated.

## Claims

1. A device (100) comprising:

an antenna (108);

a first front-end communication section (114,

- 304) that is configured to communicate via a Wifi communication using the antenna (108);  
 a second front-end communication section (114, 306) that is configured to communicate via ultra-high frequency (UHF) radio-frequency identification (RFID) communication using the antenna (108);  
 a first switch (302) configured to select either the first front-end communication section (114, 304) or the second front-end communication section (114, 306), wherein the first front-end communication section (114, 304) comprises a second switch (314) configured for transmit/receive (Tx/Rx) switching for the Wifi communication and wherein the second front-end communication section (114, 306) comprises an isolator (320) configured to isolate transmission and reception paths for the UHF RFID communication; and  
 a controller (110) configured to control the first switch (302), the controller (110) being coupled to a transmitter (102, 310) and a receiver (106, 312) of the device to output a data signal to either the first front-end communication section (114, 304) or the second front-end communication section (114, 306) based on the selection by the first switch (302), wherein the data signal is output to the antenna (108) to communicate via Wifi communication and the controller (110) is configured to control the second switch (314) when the first switch (302) is controlled to select the first front-end communication section (114, 304) and wherein the data signal is output to the antenna (108) to communicate via the UHF RFID communication when the first switch (302) is controlled to select the second front-end communication section (114, 306).
2. The device of claim 1, wherein the second switch (314) is changed on when the first switch (302) has selected the first front-end communication section (114, 304).
  3. The device of claim 1, wherein the antenna (108) is the only antenna (108) used by both of the first front-end communication section (114, 304) and the second front-end communication section (114, 306), and wherein common transmit/receive circuitry is used by both of the first front-end communication section (114, 304) and the second front-end communication (114, 306) section but not at the same time.
  4. The device of claim 1, wherein the isolator (320) is connected to the antenna (108) through the first switch (302).
  5. The device of claim 1, wherein the first switch (302) is a three to six switch selectable between first and second states corresponding to the communication method for the first front-end communication section (114, 304) and the communication method for the second front-end communication section (114, 306).
  6. The device of claim 1, wherein the device further includes a power amplifier (314) connected to an input of the first switch (302).
  7. The device of claim 1, further including a band-pass filter (316) connected between the first switch (302) and the antenna (108).
  8. The device of claim 1, wherein the antenna (108) comprises a single antenna (108) common to both the first front-end communication section (114, 304) and the second front-end communication section (114, 306).
  9. The device of claim 1, wherein the first switch (302) comprises an RF switch.
  10. The device of claim 1, wherein the first front-end communication section (114, 304) is configured to communicate using an IEEE 802.11 ah communication protocol and the second front-end communication section (114, 306) is configured to communicate using a UHF RFID protocol.
  11. The device of claim 1, wherein the device is a radio that includes:  
 a single transmit and receive communication chipset configured to operate in an RFID reader and to operate for WiFi communication and radio-frequency identification (RFID) communication, wherein the single transmit and receive communication chipset is switchable between the WiFi communication and RFID communication to communicate using the antenna (108).
  12. The device of claim 11, wherein the single transmit and receive communication chipset comprises reconfigurable communication paths that are dynamically reconfigured.
  13. A method comprising the steps of:  
 sending a control signal to a first switch (302) of a reconfigurable front-end of a radio via a communication line (604), wherein the reconfigurable front-end of the radio comprises a first front-end communication section (114, 304) that is configured to communicate via a Wifi communication using an antenna (108) and a second front-end communication section (114, 306) that is configured to communicate via ultra-high frequency (UHF) radio-frequency identification



(RFID) communication using the antenna (108); based on the control signal received by the first switch (302), switching a state of the reconfigurable front-end of the radio to change between the first front-end communication section (114, 304) and the second front-end communication section (114, 306), wherein the first front-end communication section (114, 304) further comprises a second switch (314) configured for transmit/receive (Tx/Rx) switching for the Wifi communication and wherein the second front-end communication section (114, 306) comprises an isolator (320) configured to isolate transmission and reception paths for the UHF RFID communication; and configuring a controller (110) configured to control the first switch (302), the controller (110) being coupled to a transmitter (102, 310) and a receiver (106, 312) of the device to output a data signal to either the first front-end communication section (114, 304) or the second front-end communication section (114, 306) based on the selection by the first switch (302), wherein the data signal is output to the antenna (108) to communicate via Wifi communication and the controller (110) is configured to control the second switch (314) when the first switch (302) is controlled to select the first front-end communication section (114, 304) and wherein the data signal is output to the antenna (108) to communicate via the UHF RFID communication when the first switch (302) is controlled to select the second front-end communication section (114, 306).

14. The method of claim 13, wherein the reconfigurable front-end comprises reconfigurable communication paths.
15. The method of claim 14, wherein the reconfigurable front-end comprises a WiFi switch and the isolator (320) in different communication paths.

### Patentansprüche

1. Vorrichtung (100), umfassend:

eine Antenne (108);  
 einen ersten Frontend-Kommunikationsabschnitt (114, 304), der für die Kommunikation über eine Wifi-Kommunikation unter Verwendung der Antenne (108) konfiguriert ist;  
 einen zweiten Frontend-Kommunikationsabschnitt (114, 306), der für die Kommunikation über eine Ultrahochfrequenz-(UHF)-Funkfrequenzidentifikations-(RFID)-Kommunikation unter Verwendung der Antenne (108) konfiguriert ist;

einen ersten Schalter (302), der zur Auswahl entweder des ersten Frontend-Kommunikationsabschnitts (114, 304) oder des zweiten Frontend-Kommunikationsabschnitts (114, 306) konfiguriert ist, wobei der erste Frontend-Kommunikationsabschnitt (114, 304) einen zweiten Schalter (314) umfasst, der zur Sende-/Empfangsumschaltung (Tx/Rx) für die Wifi-Kommunikation konfiguriert ist, und wobei der zweite Frontend-Kommunikationsabschnitt (114, 306) einen Isolator (320) umfasst, der zur Isolierung von Sende- und Empfangswegen für die UHF-RFID-Kommunikation konfiguriert ist; und eine Steuerung (110), die zum Steuern des ersten Schalters (302) konfiguriert ist, wobei die Steuerung (110) mit einem Sender (102, 310) und einem Empfänger (106, 312) der Vorrichtung gekoppelt ist, um basierend auf der Auswahl durch den ersten Schalter (302) ein Datensignal entweder an den ersten Frontend-Kommunikationsabschnitt (114, 304) oder den zweiten Frontend-Kommunikationsabschnitt (114, 306) auszugeben, wobei das Datensignal an die Antenne (108) ausgegeben wird, um über Wifi-Kommunikation zu kommunizieren, und die Steuerung (110) zum Steuern des zweiten Schalters (314) konfiguriert ist, wenn der erste Schalter (302) zur Auswahl des ersten Frontend-Kommunikationsabschnitts (114, 304) gesteuert wird, und wobei das Datensignal an die Antenne (108) ausgegeben wird, um über die UHF-RFID-Kommunikation zu kommunizieren, wenn der erste Schalter (302) zur Auswahl des zweiten Frontend-Kommunikationsabschnitts (114, 306) gesteuert wird.

2. Vorrichtung nach Anspruch 1, wobei der zweite Schalter (314) eingeschaltet wird, wenn der erste Schalter (302) den ersten Frontend-Kommunikationsabschnitt (114, 304) ausgewählt hat.
3. Vorrichtung nach Anspruch 1, wobei die Antenne (108) die einzige Antenne (108) ist, die sowohl von dem ersten Frontend-Kommunikationsabschnitt (114, 304) als auch von dem zweiten Frontend-Kommunikationsabschnitt (114, 306) verwendet wird, und wobei eine gemeinsame Sende-/Empfangsumschaltung sowohl von dem ersten Frontend-Kommunikationsabschnitt (114, 304) als auch von dem zweiten Frontend-Kommunikationsabschnitt (114, 306) verwendet wird, jedoch nicht gleichzeitig.
4. Vorrichtung nach Anspruch 1, wobei der Isolator (320) über den ersten Schalter (302) mit der Antenne (108) verbunden ist.
5. Vorrichtung nach Anspruch 1, wobei der erste Schalter (302) ein Drei- bis Sechsschalter ist, der zwischen

- einem ersten und einem zweiten Zustand entsprechend dem Kommunikationsverfahren für den ersten Frontend-Kommunikationsabschnitt (114, 304) und dem Kommunikationsverfahren für den zweiten Frontend-Kommunikationsabschnitt (114, 306) ausgewählt werden kann. 5
- 6.** Vorrichtung nach Anspruch 1, wobei die Vorrichtung ferner einen Leistungsverstärker (314) einschließt, der mit einem Eingang des ersten Schalters (302) verbunden ist. 10
- 7.** Vorrichtung nach Anspruch 1, ferner einschließend ein Bandpassfilter (316), das zwischen dem ersten Schalter (302) und der Antenne (108) verbunden ist. 15
- 8.** Vorrichtung nach Anspruch 1, wobei die Antenne (108) eine einzelne Antenne (108) umfasst, die sowohl dem ersten Frontend-Kommunikationsabschnitt (114, 304) als auch dem zweiten Frontend-Kommunikationsabschnitt (114, 306) gemeinsam ist. 20
- 9.** Vorrichtung nach Anspruch 1, wobei der erste Schalter (302) einen HF-Schalter umfasst. 25
- 10.** Vorrichtung nach Anspruch 1, wobei der erste Frontend-Kommunikationsabschnitt (114, 304) so konfiguriert ist, dass er unter Verwendung eines IEEE 802.11 ah-Kommunikationsprotokolls kommuniziert und der zweite Frontend-Kommunikationsabschnitt (114, 306) so konfiguriert ist, dass er unter Verwendung eines UHF-RFID-Protokolls kommuniziert. 30
- 11.** Vorrichtung nach Anspruch 1, wobei die Vorrichtung ein Funkgerät ist, das einschließt: 35  
einen einzelnen Sende- und Empfangskommunikations-Chipsatz, der so konfiguriert ist, dass er in einem RFID-Lesegerät arbeitet und für die WiFi-Kommunikation und die Radiofrequenz-Identifikationskommunikation (RFID) arbeitet, wobei der einzelne Sende- und Empfangskommunikations-Chipsatz zwischen der WiFi-Kommunikation und der RFID-Kommunikation umschaltbar ist, um unter Verwendung der Antenne (108) zu kommunizieren. 40  
45
- 12.** Vorrichtung nach Anspruch 11, wobei der einzelne Sende- und Empfangskommunikations-Chipsatz rekonfigurierbare Kommunikationswege umfasst, die dynamisch rekonfiguriert werden. 50
- 13.** Verfahren, umfassend die folgenden Schritte:  
Senden eines Steuersignals an einen ersten Schalter (302) eines rekonfigurierbaren Frontends eines Funkgeräts über eine Kommunikationsleitung (604), wobei das rekonfigurierbare Frontend des Funkgeräts einen ersten Frontend-Kommunikationsabschnitt (114, 304), der für die Kommunikation über eine Wifi-Kommunikation unter Verwendung einer Antenne (108) konfiguriert ist, und einen zweiten Frontend-Kommunikationsabschnitt (114, 306), der für die Kommunikation über eine Ultrahochfrequenz-(UHF)-Funkfrequenzidentifikations-(RFID)-Kommunikation unter Verwendung der Antenne (108) konfiguriert ist, umfasst; basierend auf dem Steuersignal, das von dem ersten Schalter (302) empfangen wird, Umschalten eines Zustands des rekonfigurierbaren Frontends des Funkgeräts, um zwischen dem ersten Frontend-Kommunikationsabschnitt (114, 304) und dem zweiten Frontend-Kommunikationsabschnitt (114, 306) zu wechseln, wobei der erste Frontend-Kommunikationsabschnitt (114, 304) ferner einen zweiten Schalter (314) umfasst, der zur Sende-/Empfangsumschaltung (Tx/Rx) für die Wifi-Kommunikation konfiguriert ist, und wobei der zweite Frontend-Kommunikationsabschnitt (114, 306) einen Isolator (320) umfasst, der zur Isolierung von Sende- und Empfangswegen für die UHF-RFID-Kommunikation konfiguriert ist; und Konfigurieren einer Steuerung (110), die zum Steuern des ersten Schalters (302) konfiguriert ist, wobei die Steuerung (110) mit einem Sender (102, 310) und einem Empfänger (106, 312) der Vorrichtung gekoppelt ist, um basierend auf der Auswahl durch den ersten Schalter (302) ein Datensignal entweder an den ersten Frontend-Kommunikationsabschnitt (114, 304) oder den zweiten Frontend-Kommunikationsabschnitt (114, 306) auszugeben, wobei das Datensignal an die Antenne (108) ausgegeben wird, um über Wifi-Kommunikation zu kommunizieren, und die Steuerung (110) zum Steuern des zweiten Schalters (314) konfiguriert ist, wenn der erste Schalter (302) zur Auswahl des ersten Frontend-Kommunikationsabschnitts (114, 304) gesteuert wird, und wobei das Datensignal an die Antenne (108) ausgegeben wird, um über die UHF-RFID-Kommunikation zu kommunizieren, wenn der erste Schalter (302) zur Auswahl des zweiten Frontend-Kommunikationsabschnitts (114, 306) gesteuert wird. 55
- 14.** Verfahren nach Anspruch 13, wobei das rekonfigurierbare Frontend rekonfigurierbare Kommunikationswege umfasst.
- 15.** Verfahren nach Anspruch 14, wobei das rekonfigurierbare Frontend einen WiFi-Schalter und den Isolator (320) in verschiedenen Kommunikationswegen umfasst.

## Revendications

### 1. Dispositif (100) comprenant :

une antenne (108) ;  
 une première section de communication frontale (114, 304) qui est conçue pour communiquer via une communication Wifi en utilisant l'antenne (108) ;  
 une seconde section de communication frontale (114, 306) qui est conçue pour communiquer via une communication d'identification par radiofréquence (RFID) ultra-haute fréquence (UHF) en utilisant l'antenne (108) ;  
 un premier commutateur (302) conçu pour sélectionner soit la première section de communication frontale (114, 304) soit la seconde section de communication frontale (114, 306), la première section de communication frontale (114, 304) comprenant un second commutateur (314) conçu pour la commutation d'émission/réception (Tx/Rx) pour la communication Wifi et la seconde section de communication frontale (114, 306) comprenant un isolateur (320) conçu pour isoler les voies de transmission et de réception pour la communication RFID UHF ; et  
 un dispositif de commande (110) conçu pour commander le premier commutateur (302), le dispositif de commande (110) étant couplé à un émetteur (102, 310) et à un récepteur (106, 312) du dispositif pour émettre un signal de données soit à la première section de communication frontale (114, 304) soit à la seconde section de communication frontale (114, 306) d'après la sélection par le premier commutateur (302), le signal de données étant émis vers l'antenne (108) pour communiquer via communication Wifi et le dispositif de commande (110) étant conçu pour commander le second commutateur (314) lorsque le premier commutateur (302) est commandé pour sélectionner la première section de communication frontale (114, 304) et le signal de données étant émis vers l'antenne (108) pour communiquer via la communication RFID UHF lorsque le premier commutateur (302) est commandé pour sélectionner la seconde section de communication frontale (114, 306).

2. Dispositif selon la revendication 1, dans lequel le second commutateur (314) est activé lorsque le premier commutateur (302) a sélectionné la première section de communication frontale (114, 304).

3. Dispositif selon la revendication 1, dans lequel l'antenne (108) est la seule antenne (108) utilisée à la fois par la première section de communication frontale (114, 304) et par la seconde section de communication frontale (114, 306) et dans lequel des cir-

cuits communs d'émission/réception sont utilisés à la fois par la première section de communication frontale (114, 304) et par la seconde section de communication frontale (114, 306) mais pas en même temps.

4. Dispositif selon la revendication 1, dans lequel l'isolateur (320) est connecté à l'antenne (108) par l'intermédiaire du premier commutateur (302).

5. Dispositif selon la revendication 1, dans lequel le premier commutateur (302) est un commutateur trois à six sélectionnable entre des premier et second états correspondant au procédé de communication pour la première section de communication frontale (114, 304) et au procédé de communication pour la seconde section de communication frontale (114, 306).

6. Dispositif selon la revendication 1, le dispositif comportant en outre un amplificateur de puissance (314) connecté à une entrée du premier commutateur (302).

7. Dispositif selon la revendication 1, comportant en outre un filtre passe-bande (316) connecté entre le premier commutateur (302) et l'antenne (108).

8. Dispositif selon la revendication 1, dans lequel l'antenne (108) comprend une seule antenne (108) commune à la fois à la première section de communication frontale (114, 304) et à la seconde section de communication frontale (114, 306).

9. Dispositif selon la revendication 1, dans lequel le premier commutateur (302) comprend un commutateur RF.

10. Dispositif selon la revendication 1, dans lequel la première section de communication frontale (114, 304) est conçue pour communiquer en utilisant un protocole de communication IEEE 802.11 ah et où la seconde section de communication frontale (114, 306) est conçue pour communiquer en utilisant un protocole RFID UHF.

11. Dispositif selon la revendication 1, le dispositif étant une radio qui comporte :  
 un jeu de puces de communication d'émission et de réception unique, conçu pour fonctionner dans un lecteur RFID et pour fonctionner pour une communication WiFi et pour une communication d'identification par radiofréquence (RFID), le jeu de puces de communication d'émission et de réception unique pouvant être commuté entre la communication WiFi et la communication RFID pour communiquer à l'aide de l'antenne (108).

12. Dispositif selon la revendication 11, dans lequel l'uni-

que jeu de puces de communication d'émission et de réception comprend des voies reconfigurables de communication, qui sont dynamiquement reconfigurées.

**13.** Procédé comprenant les étapes suivantes :

envoi d'un signal de commande à un premier commutateur (302) d'un circuit frontal reconfigurable d'une radio via une ligne de communication (604), le circuit frontal reconfigurable de la radio comprenant une première section de communication frontale (114, 304) qui est conçue pour communiquer via une communication Wifi en utilisant une antenne (108) et une seconde section de communication frontale (114, 306) qui est conçue pour communiquer via une communication d'identification par radiofréquence (RFID) ultra-haute fréquence (UHF) en utilisant l'antenne (108) ;  
 d'après le signal de commande reçu par le premier commutateur (302), commutation d'un état du circuit frontal reconfigurable de la radio pour changer entre la première section de communication frontale (114, 304) et la seconde section de communication frontale (114, 306), la première section de communication frontale (114, 304) comprenant en outre un second commutateur (314) conçu pour la commutation d'émission/réception (Tx/Rx) pour la communication Wifi et la seconde section de communication frontale (114, 306) comprenant un isolateur (320) conçu pour isoler les voies de transmission et de réception pour la communication RFID UHF ; et  
 configuration d'un dispositif de commande (110) conçu pour commander le premier commutateur (302), le dispositif de commande (110) étant couplé à un émetteur (102, 310) et à un récepteur (106, 312) du dispositif pour émettre un signal de données soit vers la première section de communication frontale (114, 304) soit vers la seconde section de communication frontale (114, 306) selon la sélection par le premier commutateur (302), le signal de données étant émis vers l'antenne (108) pour communiquer via une communication Wifi et le dispositif de commande (110) étant conçu pour commander le second commutateur (314) lorsque le premier commutateur (302) est commandé pour sélectionner la première section de communication frontale (114, 304) et le signal de données étant émis vers l'antenne (108) pour communiquer via la communication RFID UHF lorsque le premier commutateur (302) est commandé pour sélectionner la seconde section de communication frontale (114, 306).

**14.** Procédé selon la revendication 13, dans lequel le circuit frontal reconfigurable comprend des voies reconfigurables de communication.

**15.** Procédé selon la revendication 14, dans lequel le circuit frontal reconfigurable comprend un commutateur WiFi et l'isolateur (320) dans différentes voies de communication.

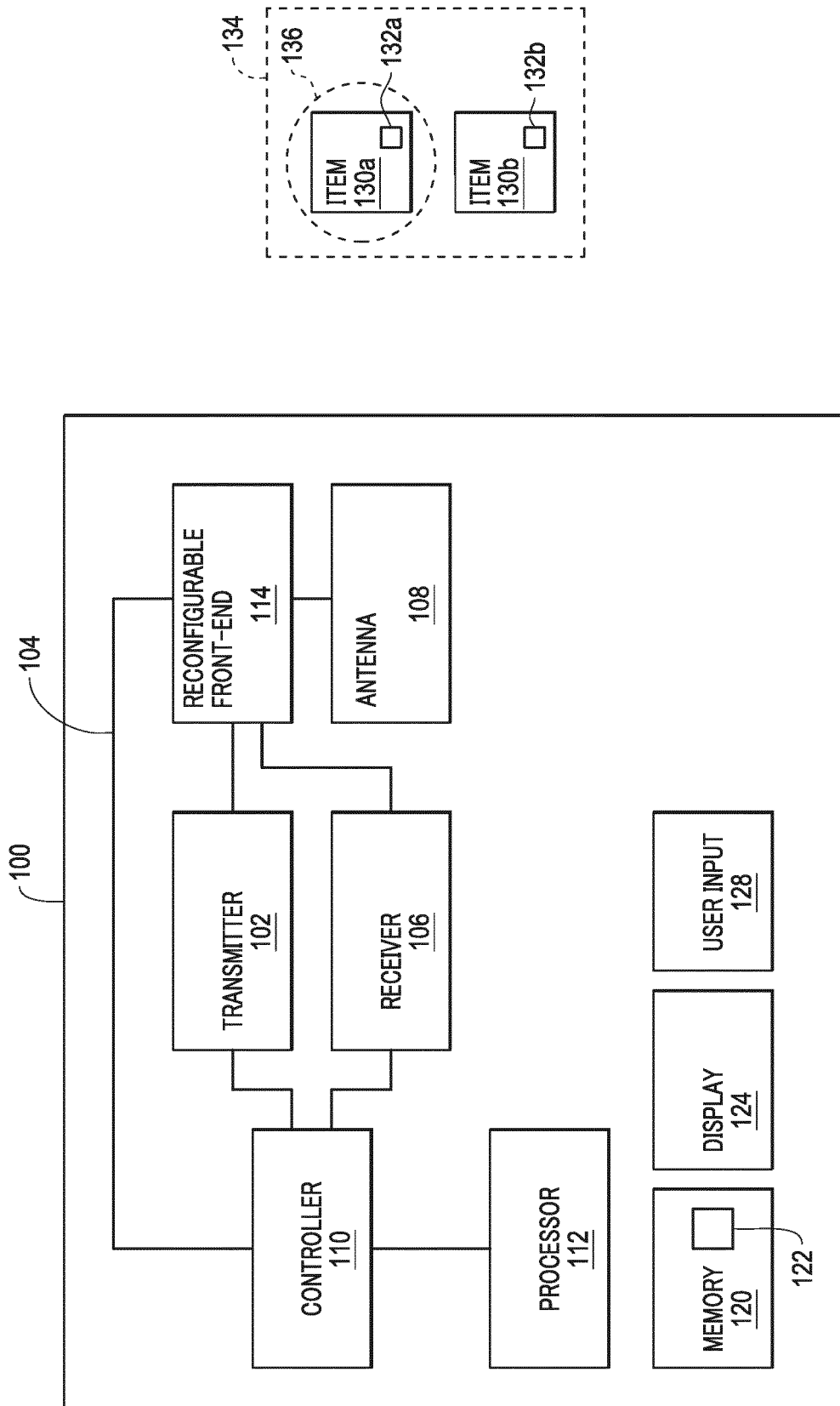

FIG. 1

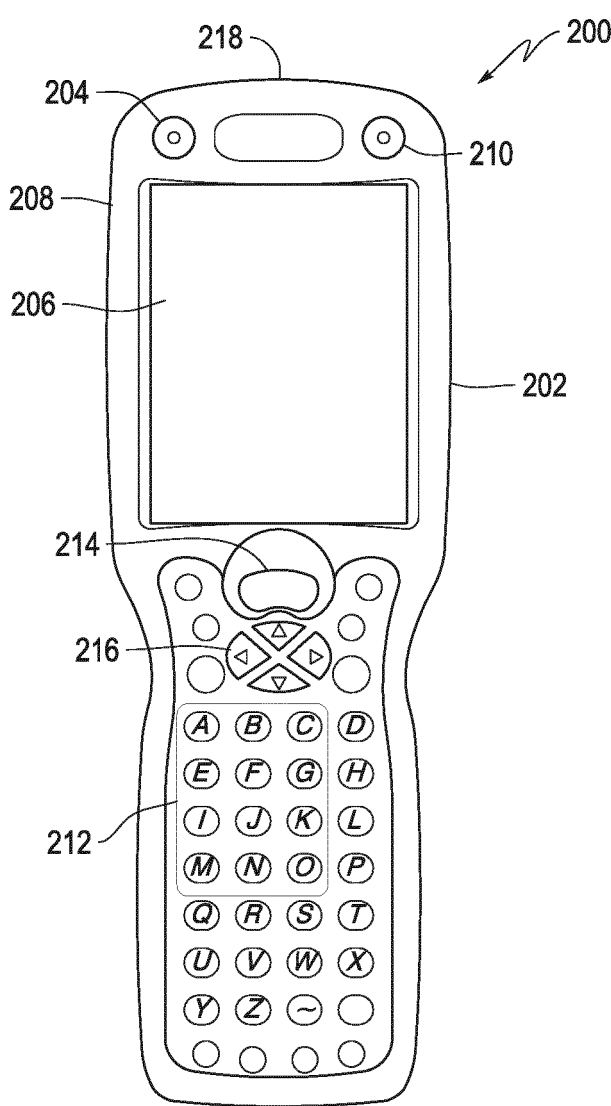

FIG. 2A

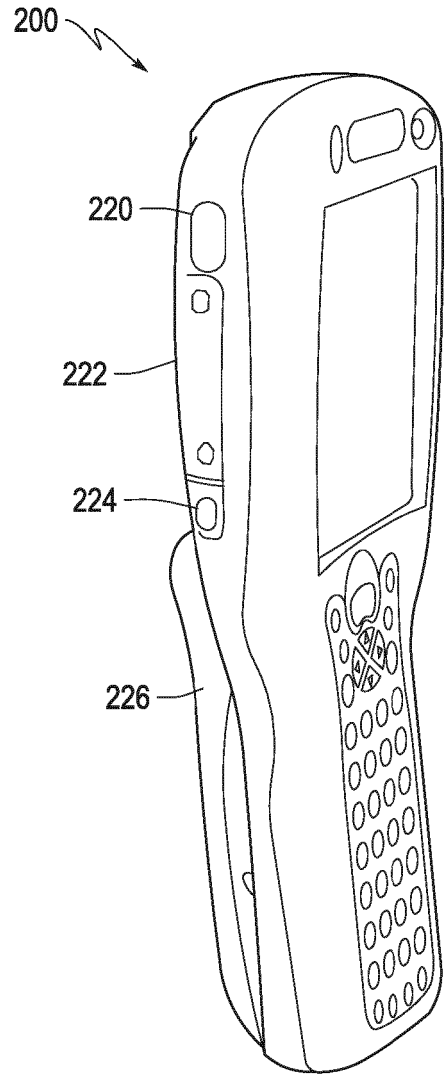

FIG. 2B

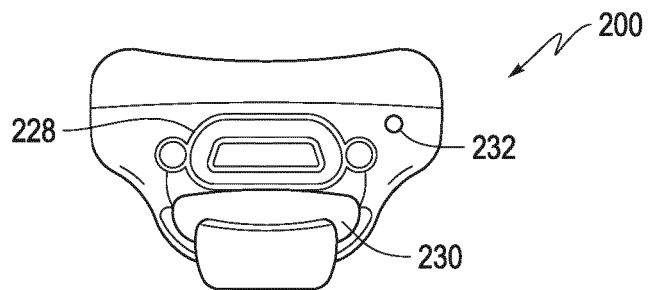

FIG. 2C

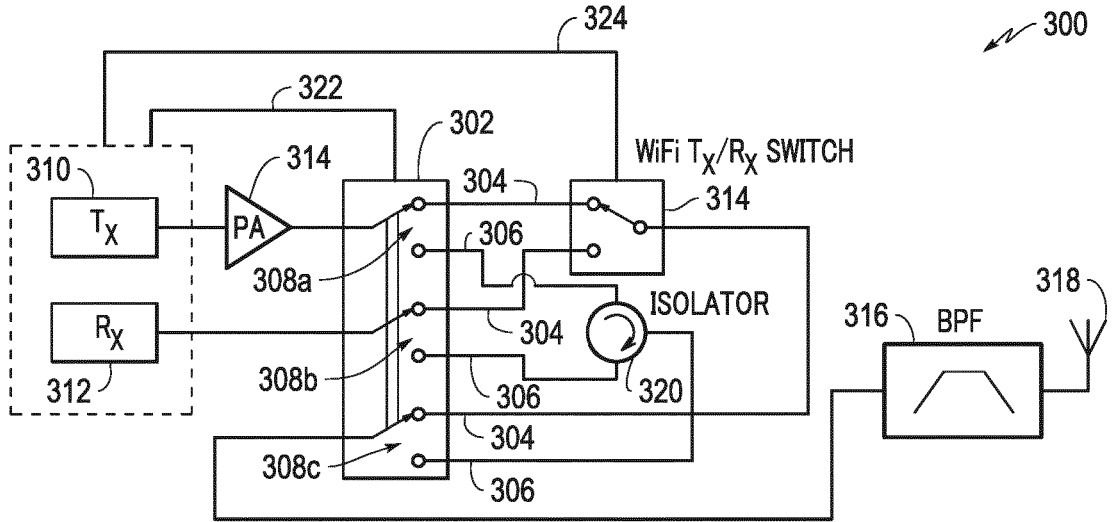

FIG. 3

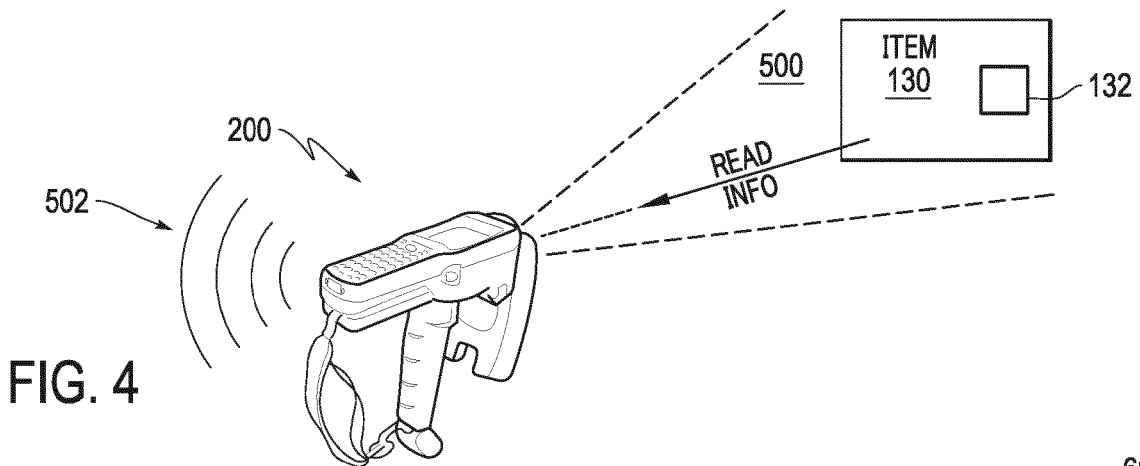

FIG. 4

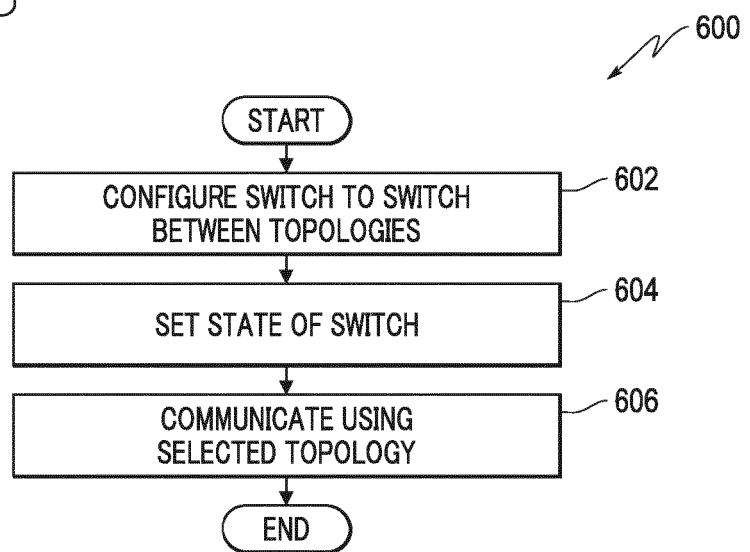

FIG. 5

**REFERENCES CITED IN THE DESCRIPTION**

*This list of references cited by the applicant is for the reader's convenience only. It does not form part of the European patent document. Even though great care has been taken in compiling the references, errors or omissions cannot be excluded and the EPO disclaims all liability in this regard.*

**Patent documents cited in the description**

- US 2010137024 A1 [0002]
- US 2006238306 A1 [0003]