

A Novel Mode Content Analysis Technique for Antennas in Multimode Waveguides

Pavel V. Nikitin, *Member, IEEE*, Daniel D. Stancil, *Senior Member, IEEE*, Ahmet G. Cepni, *Student Member, IEEE*, Ariton E. Xhafa, *Student Member, IEEE*, Ozan K. Tonguz, *Member, IEEE*, and Dagfin Brodtkorb, *Member, IEEE*

Abstract—This paper presents a novel technique for analyzing the mode content excited by antennas placed in multimode waveguides. The technique is based on measuring the frequency response between the two antennas coupled into a waveguide and using that information to extract the mode content generated by the transmitting antenna. The technique is applicable to cases in which the mode amplitudes are approximately constant over the frequency range of interest. This method is valuable for determining the mode mix generated by arbitrary transmitting antennas in a multimode waveguide propagation environment. An example of such an environment is heating, ventilation, and air-conditioning (HVAC) ducts used for indoor communications, where an important antenna characteristic is the mode sensitivity (analogous to the antenna directive gain in free space). We validate our technique with the example of a monopole probe antenna coupled into a multimode cylindrical HVAC duct.

Index Terms—Antennas, indoor radio communication, microwave measurements, multimode waveguides.

I. INTRODUCTION

AN ANTENNA radiating in free space can be characterized by its directive gain, which is a function of angular direction. In waveguides, the only direction of field propagation is along the waveguide and the propagating field can always be decomposed into a finite sum of normal modes. The characteristic analogous to the directive gain is mode sensitivity gain, which can be defined as the power radiated into a given mode, normalized by the average radiated power per mode. Thus, an antenna in a uniform multimode waveguide can be characterized by the waveguide mode distribution that it excites.

The application that stimulated our interest in mode content analysis techniques for antennas in multimode waveguides is indoor communications via heating, ventilation, and air-conditioning (HVAC) ducts. Using the HVAC duct system in buildings for signal distribution is a promising way to provide a high-speed network access to offices [1]. A typical HVAC duct system is a complex network of hollow metal pipes of rectangular or circular cross section, which may extend to hundreds of meters. These pipes behave as multimode waveguides when

driven at microwave frequencies. The signal can be coupled into and out of the ducts using coaxially fed antennas mounted on duct walls.

Multimode dispersion and redistribution of energy between different modes in various waveguide system elements can significantly affect the capacity and the signal-to-noise ratio in the waveguide communication system [2]. Therefore, selection of a mode distribution that results in reduced multimode dispersion and minimum attenuation is very important in waveguide communications. Many mode selection techniques are known, but most of them involve modifying the waveguide shape or structure [3]. Desired mode selectivity can also be obtained by varying the antenna parameters. To build an effective waveguide communication system, it is critical to use antennas that excite a desired mode distribution that has favorable propagation characteristics. It is also important to have an ability to measure the mode content excited by the transmitting antenna and traveling in the waveguide.

When experimentally characterizing the performance of various antennas in an HVAC duct system, the mode content must be measured multiple times at various locations in ducts of different diameter. That means that the mode content measurement technique must be simple, efficient, and least destructive to an existing duct system. Moreover, only the modes to which a receiving antenna is the most sensitive directly affect the quality of communication and are important for analysis. This paper describes a novel technique for the mode content analysis that satisfies all of the aforementioned criteria.

The remainder of this paper is organized as follows. Section II covers the previous work in the area of mode content measurement. The novel mode content analysis technique developed by the authors is described in Section III. Section IV presents the validation of the technique. Section V contains the discussion. Conclusions are given in Section VI.

II. PREVIOUS WORK

Existing mode content measurement approaches can be divided into four major groups: scanning the field pattern, using mode-selective couplers, measuring open-end radiation pattern, and array processing. Below, we briefly describe each one separately.

The scanning field pattern technique has been used by many researchers. Forrer and Tomiyasu [4] used a moving probe to measure the electric-field magnitude and phase at the walls of a waveguide and a Fourier analysis to compute the power flow in each mode. Fixed multiple-probe arrays were used by Price [5],

Manuscript received April 18, 2003.

P. V. Nikitin is with the Department of Electrical Engineering, University of Washington, Seattle, WA 98195-2500 USA (e-mail: nikitin@ee.washington.edu).

D. D. Stancil, A. G. Cepni, A. E. Xhafa, and O. K. Tonguz are with the Department of Electrical and Computer Engineering, Carnegie-Mellon University, Pittsburgh, PA 15213-3890 USA (e-mail: stancil@andrew.cmu.edu; tonguz@andrew.cmu.edu; axhafa@andrew.cmu.edu; acepni@andrew.cmu.edu).

D. Brodtkorb is with Asea Brown Boveri Corporate Research, N-1735 Billingstad, Norway (e-mail: dagfin.brodtkorb@no.abb.com).

Digital Object Identifier 10.1109/TMTT.2003.820171

Taub [6], and Levinson and Rubinstein [7]. Klinger [8] used a fixed probe and a moving short termination to measure the multimode content. Glock and van Rienen [9] used a fixed probe, a fixed termination, but moving (adjustable length) waveguide to perform necessary measurements.

Mode-selective coupling has been used by Lewis [10] and Beck [11], who employed a series of specially designed mode couplers to couple a mode to its own output port. Seguinot *et al.* [12] used a mode coupling technique for characterizing multimode microstrip lines.

Measuring the radiation pattern of an open-ended waveguide has typically been used in high-power microwave engineering for extracting the mode content of a high-power source (magnetron, gyrotron, etc.) [13] and in application to analysis of waveguide horn antennas [14].

Array processing involves measuring the signal at the elements of an antenna array mounted on the waveguide and using those measurements for mode content extraction. This method is somewhat similar to the field scanning technique. To achieve good results, antenna locations must be carefully chosen and sometimes even optimized in the process of measurement. An excellent example of using an antenna array for mode measurement is given by Baird *et al.* [15]. Measurements using a loop antenna oriented at different angles are described in [16].

All of the techniques described above require a complicated experimental setup and a lengthy process of mode content measurement. Below we describe a novel technique for mode content analysis that requires only one sensing antenna for determining the frequency-averaged mode content in the frequency range of interest. Measurements performed at a few different frequencies provide the necessary information for resolving the mix of several modes. A brief description of this technique has previously appeared in [17].

III. TECHNIQUE

A. Concept Description

Consider a conceptual setup shown in Fig. 1: a multimode waveguide with two coaxially fed antennas coupled into it, where one antenna is transmitting, and another antenna is sensing the mode content. Assume that the waveguide is straight and is terminated on both ends with matched loads that prevent end reflections. The mode mix generated by the transmitting antenna is to be determined using the sensing antenna.

The information needed for mode content determination is the frequency response between the two antennas, which can be measured by a network analyzer. Two assumptions critical for our method are: 1) the mode amplitudes excited by the transmitting antenna are weak functions of frequency and 2) the coupling between the waveguide modes and receiving antenna is known and can be calculated.

Fixing a sensing antenna position and sweeping the frequency allows one to obtain independent measurements, somewhat similar to fixing the frequency and moving the antenna along a slit in a waveguide wall. The system frequency response values measured at different points across the band can be used to find a set of approximate mode amplitudes, which best approximate the measured data and are constant over the band.

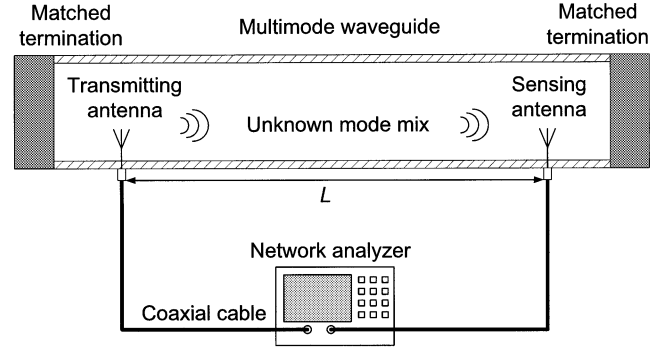

Fig. 1. Setup for measurement of the mode mix generated by the transmitting antenna.

B. Details

Assume that N modes can propagate in our waveguide (if antennas are sufficiently far apart, evanescent modes can be neglected) and $\vec{X}(\omega)$ is the unknown N -dimensional vector of complex mode amplitudes excited by the transmitting antenna. The frequency response between the transmitting and receiving antennas can be written in terms of $\vec{X}(\omega)$ as the following scalar product:

$$\vec{X}(\omega)\vec{A}(\omega) = H(\omega) \quad (1)$$

where the frequency-dependent vector $\vec{A}(\omega)$ describes a coupling between the waveguide modes and the sensing (receiving) antenna. If mode amplitudes $\vec{X}(\omega)$ are weak functions of frequency in the range of interest, they can be approximated as constants as follows:

$$\vec{X}(\omega) \approx [X_1, X_2, \dots, X_N]. \quad (2)$$

Evaluating $H(\omega)$ at M discrete frequency points, we can rewrite (1) as

$$\vec{X}\hat{A} = \vec{H} \quad (3)$$

where the M -dimensional vector \vec{H} is

$$\vec{H} = [H(\omega_1), H(\omega_2), \dots, H(\omega_M)] \quad (4)$$

and the matrix \hat{A} consists of elements $A_{nm} = A_n(\omega_m)$.

The linear system given by (3) contains N unknowns and can be solved for \vec{X} if the number of independent frequency measurement points is greater or equal to the number of modes to be determined.

C. Matrix Calculation

A matrix element A_{nm} represents the coupling of mode n excited by the transmitting antenna into the receiving antenna at the frequency ω_m . For a generic antenna in a straight waveguide with matched ends, it can be calculated in the following way.

Assume that mode n is excited by the transmitting antenna with an amplitude X_n . The amplitude of this mode at the receiving antenna can be found as $X_n e^{-\gamma_n L}$, where γ_n is the waveguide propagation constant of mode n and L is the distance between the antennas. The field due to this mode induces

a current I_n in the receiving antenna, which can be found using a standard microwave technique for probe-waveguide coupling (e.g., see Collin [18] and Pozar [19]) as

$$I_n = -\frac{4p_n X_n e^{-\gamma_n L}}{\mathcal{I}_n} \quad (5)$$

where p_n is the normalized power carried by mode n in one direction and $\mathcal{I}_n = \int_S \vec{e}_n \cdot \vec{j} ds$ is the integral that describes the interaction of the normalized current distribution \vec{j} on the antenna surface S_a with the normalized electric field of mode n .

The current I_n due to mode n causes the voltage $I_n Z_n$ to appear on the receiving (sensing) antenna, where Z_n is the sensing antenna impedance in mode n . Taking into account the mismatch between the internal impedance Z_o of the network analyzer (and matching coaxial cable) and the total impedance of the sensing antenna Z_a , one can write the voltage V_n seen by the network analyzer due to mode n as

$$V_n = I_n Z_n \frac{Z_o}{(Z_o + Z_a)}. \quad (6)$$

Combining (5) and (6), one can obtain the following expression for matrix elements A_{nm} :

$$A_{nm} = K \frac{Z_o}{(Z_o + Z_a)} \frac{Z_n p_n}{\mathcal{I}_n} e^{-\gamma_n L} \quad (7)$$

where K is the constant that does not depend on the frequency ω_m or the mode index n . It includes, for example, the effect of mismatch between the network analyzer and transmitting antenna impedances. This effect can be considered to be frequency independent in the band of interest due to our assumption that excited mode amplitudes are weak functions of frequency. The knowledge of constant K is not necessary for extracting the relative (normalized) mode distribution.

Quantities Z_a , Z_n , p_n , \mathcal{I}_n , and γ_n depend on the frequency ω_m and can be calculated for given waveguide cross section and chosen receiving antenna geometry. The analytical formulas for those quantities in a special case of monopole probe antennas in cylindrical waveguides can be obtained from [20].

D. Requirements

The accuracy of our method is affected by several factors.

First, it depends on the degree of variation with frequency of mode amplitudes excited by the transmitting antenna. This variation depends on the waveguide size, operating frequency range, transmitting antenna characteristics, and should be minimal for good extraction results. A necessary condition is that no cutoff frequencies of the analyzed modes must be near or within the frequency range of interest to avoid a strong frequency dependence of mode amplitudes.

Second, the conditioning of (3) is important. The condition number of matrix \hat{A} is a function of distance L , the characteristics of the sensing antenna, the chosen set of frequency points, and the set of modes to be extracted. Some waveguide modes may be interacting with the sensing probe antenna very weakly,

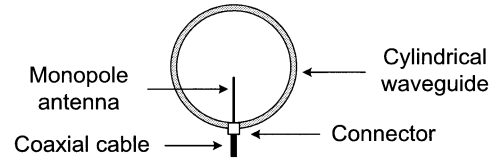

Fig. 2. Coaxially fed monopole probe antenna in a cylindrical waveguide.

and an attempt to include those modes into a mode set to be extracted can lead to an ill-conditioned matrix \hat{A} .

Third, the number of independent frequency points must be larger than the maximum number of propagating modes. The spacing distance between the independent frequency points can be estimated from the autocorrelation function $S(\omega)$ of the frequency response defined as

$$S(\omega) = \int_{\omega_1}^{\omega_2} H(\omega + y) H^*(y) dy \quad (8)$$

where ω_1 and ω_2 are the lower and upper frequencies of the band. Note that the number of points used for mode content analysis can be larger than the number of independent frequency points. As long as the rank of the system given by (3) is greater or equal to the number of modes to be extracted, a solution can be found. An overdetermined system actually results in a more accurate solution by providing a better fit of the frequency response.

IV. VALIDATION

A. Setup

To validate our mode extraction technique, we used it for experimental extraction of the mode content excited in a multimode waveguide by an antenna whose mode amplitudes can be calculated theoretically: a monopole probe antenna coupled into a cylindrical waveguide, as shown in Fig. 2. This type of coupling has been well studied [21]. Typically, a sinusoidal current distribution is assumed on such an antenna, which allows one to calculate mode amplitudes and antenna impedance as functions of waveguide diameter, operating frequency, and monopole length. Note that the monopole antenna excites all modes in phase, which means that mode amplitudes to be extracted are purely real.

For the waveguide, we used straight metal cylindrical HVAC duct of 30.5 cm (12 in) in diameter. This is a typical duct used in the U.S. The conductivity of the duct material (metal) was assumed to be 10^6 S/m. We performed measurements in the 2.4–2.5-GHz frequency range, which contains the popular unlicensed industrial, scientific, and medical (ISM) band. For 30.5-cm cylindrical ducts, this frequency range allows propagation of 17 modes and does not contain any mode cutoff frequencies. The antennas used were 3.1-cm long (approximately a quarter-wavelength at 2.45 GHz) coaxially fed monopole probes located 9.2 m apart. In the experiment, the distances from the antennas to duct ends were 0.25 and 0.38 m and the duct ends were left open.

In heavily overmoded waveguides, open ends are good approximations to matched load terminations [22]. We determined empirically (by comparing the fit of the model [20] to the data)

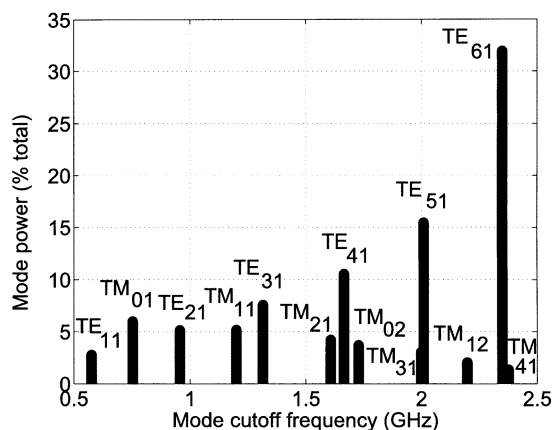

Fig. 3. Theoretically calculated mode distribution excited in a 30.5-cm cylindrical duct at 2.45 GHz by the 3.1-cm-long monopole probe antenna.

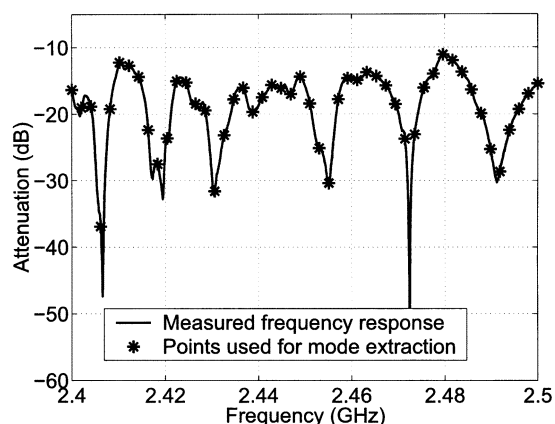

Fig. 4. Frequency response measured between two 3.1-cm monopole antennas set 9.2 m apart in a 30.5-cm straight cylindrical duct with open ends and points used for mode extraction.

that, in our case, the reflection coefficient averaged over all modes in the 2.4–2.5-GHz frequency range was on the order of 0.1.

Fig. 3 gives theoretically calculated mode distribution excited in this waveguide at 2.45 GHz by this monopole probe (details of calculation are given in [20]). Note that TE_{on} modes are not excited by the radial vertical monopole because of their circumferential electric field.

B. Measurements

Fig. 4 shows the system frequency response measured between the antennas. The observed shape of the frequency response depends on the excited mode distribution and the distance between the antennas. Interference between the modes results in maxima and minima (peaks and nulls) with specific widths, depths, and positions.

Fig. 5 shows the normalized magnitude of the autocorrelation function computed for a frequency response shown in Fig. 4. The width of the central peak at the 50% signal correlation level (dashed line) can serve as an estimate for the coherence bandwidth, which gives a spacing between independent frequency points. One can estimate from Fig. 5 that the coherence bandwidth is approximately 4.5 MHz, which means that 22 independent frequency measurements can fit into a 100-MHz band.

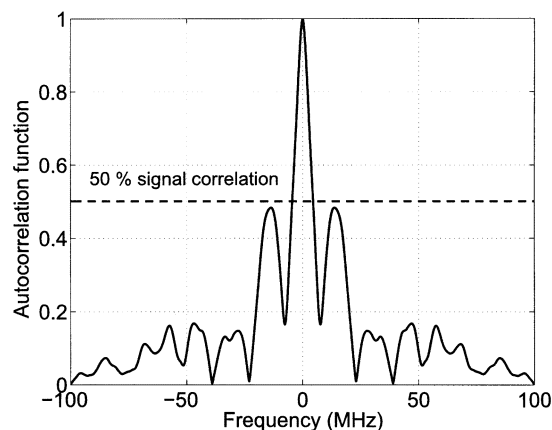

Fig. 5. Normalized magnitude of the frequency autocorrelation function for the frequency response shown in Fig. 4.

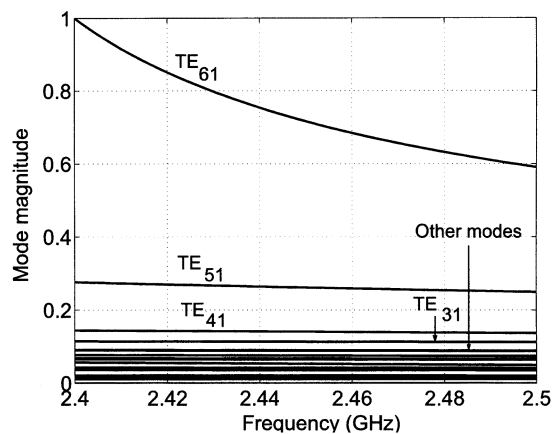

Fig. 6. Normalized magnitude of the mode amplitudes excited by 3.1-cm monopole in a 30.5-cm cylindrical waveguide as functions of frequency.

In the validation case considered here, it can be shown analytically that only the amplitude of mode TE_{61} notably changes over the 2.4–2.5-GHz frequency range. Fig. 6 shows the dependence of magnitudes of excited mode amplitudes on frequency. One can see that, indeed, the amplitude of this mode has a strong frequency dependence. Note that TE_{61} is a higher order mode, whose cutoff frequency of 2.35 GHz is very close to the lower band frequency of 2.4 GHz.

C. Results

We extracted mode amplitudes for four modes sensed best by the 3.1-cm monopole probe antenna in a 30.5-cm cylindrical waveguide: TE_{61} , TE_{51} , TE_{41} , and TE_{31} . From reciprocity, those are also the modes most excited by the same antenna when the antenna is transmitting. Table I lists the parameters of these modes: cutoff frequency, group velocity (in terms of the speed of light c), attenuation constant, radiation resistance, and power carried by the mode (in percent of total radiated power).

Linear system given by (3) was solved in MATLAB¹ using the pseudoinverse function $\text{pinv}(A)$ for 50 equally spaced frequency points in the 2.4–2.5-GHz band. The rank of the matrix given by the function $\text{rank}(A)$ was 4 (four modes were to be

¹MATLAB is a registered trademark of The Mathworks Inc., Natick, MA.

TABLE I
PARAMETERS OF THE FOUR MODES (TE_{61} , TE_{51} , TE_{41} , AND TE_{31}) MOST
EXCITED IN A 30.5-cm CYLINDRICAL DUCT BY A 3.1-cm MONOPOLE
PROBE ANTENNA AT 2.45 GHz

Mode	Cutoff (GHz)	Group velocity	Attenuation (dB/100m)	Radiation resistance (Ohm)	Power (% of total)
TE_{31}	1.316	0.847 c	2.33	2.78	7.56
TE_{41}	1.666	0.740 c	3.54	3.88	10.55
TE_{51}	2.010	0.584 c	5.64	5.68	15.44
TE_{61}	2.350	0.316 c	12.67	11.74	31.93

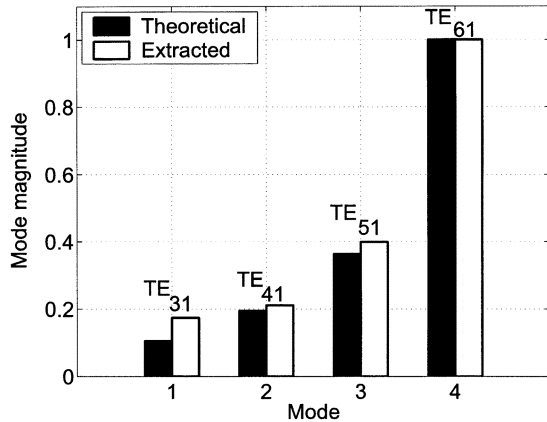

Fig. 7. Normalized magnitude of frequency-averaged theoretically calculated mode amplitudes and their values extracted from the frequency response shown in Fig. 4 using our technique.

extracted), and the condition number with respect to inversion given by the function $\text{cond}(A)$ was 2.3.

Fig. 7 shows the normalized magnitude of theoretically calculated amplitudes of the four aforementioned modes and their values extracted from the measured frequency response using our technique. Theoretical values were averaged over the frequency band. One can see that theoretical and extracted mode amplitudes are in good agreement. The largest relative error is observed for the mode TE_{31} whose interaction with the receiving antenna is weak compared to other modes. Note that the distribution of normalized mode amplitudes presented in Fig. 7 is different from the distribution of mode powers given by Fig. 3 due to the fact that mode power depends not only on the mode amplitude, but also on the power density carried by the mode.

Figs. 8 and 9 show the comparison (magnitude and phase) of the measured frequency response and the frequency response reconstructed using the extracted mode amplitudes. It is mostly the interference between these four most significantly excited modes that determines the specific locations of peaks and nulls in Fig. 8 and the slope of the curve in Fig. 9. Adding more modes introduces more variations into the frequency response (in the presence of only one mode, the frequency response magnitude would be very flat).

One can see that the measured and reconstructed curves shown in Figs. 8 and 9 are in good agreement. Differences are partially due to the fact that only four modes were used for reconstruction, partially to mode reflections from open ends, and partially to surface and shape imperfections of the HVAC

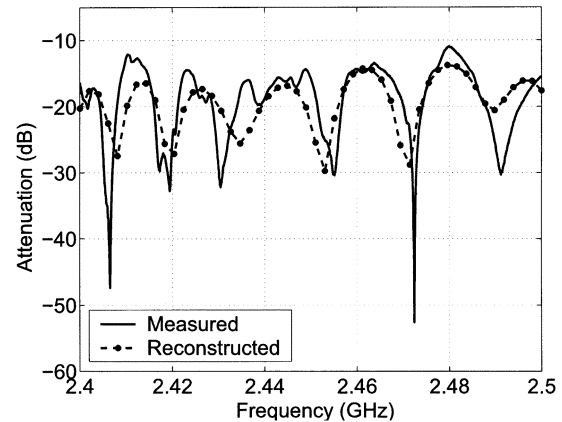

Fig. 8. Magnitude of the measured and reconstructed frequency responses.

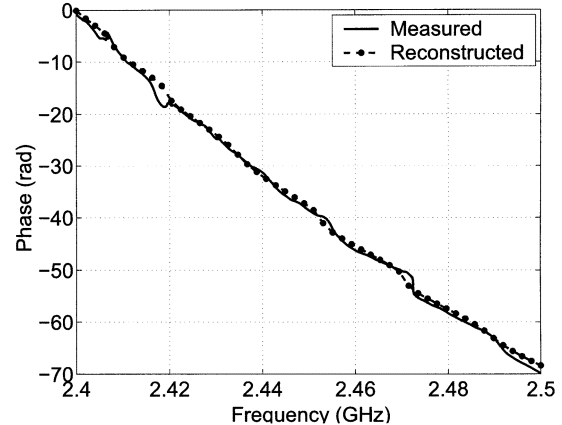

Fig. 9. Phase of the measured and reconstructed frequency responses.

duct used for measurements (dents, junctions between the sections, etc.).

V. DISCUSSION

We observed in our experiments that measured frequency response shape was rather insensitive to the small duct imperfections (dents, etc.), and the mode extraction results were consistent in various experiments that employed physically different duct sections connected together in different order. We also found that setting L to be large with respect to wavelength and choosing the modes that interact strongly with the sensing antenna improved the conditioning of matrix \hat{A} and the results of solving (3). Choosing more frequency points than

the number of modes to be extracted also helped to improve the accuracy of the solution by providing a better fit of the frequency response.

For the purposes of illustrating and validating our mode content analysis technique, we considered only a simple vertical monopole probe antenna used both for transmitting and sensing. This antenna excites and senses modes, which have a nonzero radial electric field. Other types of sensing antennas can be used as well. For example, a dipole antenna with circumferential arms that lie in the transversal plane would sense and excite modes with a circumferential electric field. Even more effective mode sensing and excitation characteristics can be obtained with a multielement antenna array, which responds well to many mode mixes.

In future HVAC communication systems, transmitting antennas may be complicated phase-fed arrays, whereas the user antennas may be simple monopoles or dipoles. Our mode content analysis technique would help to determine what modes are excited by such transmitting antennas and what the optimal mode mixes are that can be used for communicating with users.

The presented technique is not limited to straight waveguides, but requires negligible mode conversion, reflection, and scattering between the transmitting and receiving antennas (to minimize the variation of mode amplitudes with frequency) and ability to calculate coupling matrix elements.

VI. CONCLUSIONS

This paper has presented a novel mode content analysis technique that allows one to measure the mode content generated by an antenna radiating in a multimode waveguide. The ability to quickly analyze the excited mode mix is crucial to designing an antenna that not only efficiently radiates the energy into the waveguide, but also properly distributes this energy between the modes.

The presented mode analysis technique is based on using a single sensing antenna and performing measurements at different frequencies. The method works whenever the mode amplitudes excited by the transmitting antenna are weak functions of frequency. This is usually the case when there are no mode cutoff frequencies within or near the frequency range of interest.

Comparison of the mode content calculated analytically and extracted from experimental measurements confirm the validity of our technique. The main advantage of the presented method is its simplicity, which makes it very attractive for quick estimation of mode content generated by arbitrary transmitting antennas in such a multimode waveguide environment as an HVAC duct system.

REFERENCES

- [1] D. D. Stancil, O. K. Tonguz, A. Xhafa, A. Cepni, P. Nikitin, and D. Brodtkorb, "High-speed internet access via HVAC ducts: a new approach," in *Proc. IEEE Global Telecommunications Conf.*, vol. 6, San Antonio, TX, Nov. 2001, pp. 3604–3607.
- [2] P. V. Nikitin, D. D. Stancil, O. K. Tonguz, A. E. Xhafa, A. G. Cepni, and D. Brodtkorb, "Impulse response of the HVAC duct as a communication channel," *IEEE Trans. Commun.*, vol. 51, pp. 1736–1742, Oct. 2003.
- [3] M. I. Petelin, "Mode selection in high power microwave sources," *IEEE Trans. Electron Devices*, vol. 48, pp. 129–133, Jan. 2001.

- [4] M. P. Forrer and K. Tomiyasu, "Determination of higher order propagating modes in waveguide systems," *J. Appl. Phys.*, vol. 29, pp. 1040–1045, July 1958.
- [5] V. G. Price, "Measurement of harmonic power generated by microwave transmitters," *IRE Trans. Microwave Theory Tech.*, vol. MTT-7, pp. 116–120, Jan. 1959.
- [6] A. J. Taub, "A new technique for multimode power measurement," *IRE Trans. Microwave Theory Tech.*, vol. MTT-10, pp. 496–505, Nov. 1962.
- [7] D. S. Levinson and I. Rubinstein, "A technique for measuring individual modes propagating in overmoded waveguide," *IRE Trans. Microwave Theory Tech.*, vol. MTT-14, pp. 310–322, July 1966.
- [8] Y. Klinger, "The measurement of spurious modes in overmoded waveguides," *Proc. Inst. Elect. Eng.*, pt. B, vol. 106, pp. 89–93, Sept. 1959.
- [9] H.-W. Glock and U. v. Rienen, "An iterative algorithm to evaluate multimodal S -parameter measurements," *IEEE Trans. Magn.*, vol. 36, pp. 1841–1845, July 2000.
- [10] D. J. Lewis, "Mode couplers and multimode measurement techniques," *IRE Trans. Microwave Theory Tech.*, vol. MTT-7, pp. 110–116, Jan. 1959.
- [11] A. C. Beck, "Measurement techniques for multimode waveguides," *IRE Trans. Microwave Theory Tech.*, pp. 35–42, Jan. 1955.
- [12] C. Seguinot, P. Kennis, J.-F. Legier, F. Huret, E. Paleczny, and L. Hayden, "Multimode TRL—A new concept in microwave measurements: Theory and experimental verification," *IEEE Trans. Microwave Theory Tech.*, vol. 46, pp. 536–542, May 1998.
- [13] J. A. Lorbeck and R. J. Vernon, "Determination of mode content and relative phase in highly overmoded circular waveguides by open-ended radiation pattern measurement," in *Proc. IEEE AP-S Int. Symp.*, vol. 3, 1989, pp. 1251–1254.
- [14] P. McInnes and J. Ramsay, "Fresnel and Fraunhofer patterns of overmoded feeds and reflector antennas," in *IRE Int. Conv. Rec.*, vol. 14, Mar. 1966, pp. 212–243.
- [15] J. M. Baird, D. H. Roper, and R. W. Grow, "Surface array waveguide mode analyzer," in *IEEE MTT-S Int. Microwave Symp. Dig.*, vol. 1, 1992, pp. 137–140.
- [16] R. H. Johnston, "Measurement of modes in an overmoded circular waveguide," in *Proc. 40th Midwest Circuits and Systems Symp.*, vol. 1, 1998, pp. 599–602.
- [17] P. V. Nikitin, D. D. Stancil, A. G. Cepni, A. E. Xhafa, O. K. Tonguz, and D. Brodtkorb, "Novel mode content analysis technique for multimode waveguides," in *IEEE MTT-S Int. Microwave Symp. Dig.*, vol. 3, June 2003, pp. 1827–1830.
- [18] R. E. Collin, *Field Theory of Guided Waves*. New York: IEEE Press, 1990.
- [19] D. M. Pozar, *Microwave Engineering*: Wiley, 1998.
- [20] P. V. Nikitin, D. D. Stancil, A. G. Cepni, O. K. Tonguz, A. E. Xhafa, and D. Brodtkorb, "Propagation model for the HVAC duct as a communication channel," *IEEE Trans. Antennas Propagat.*, vol. 51, pp. 945–951, May 2003.
- [21] L. Lewin, "A contribution to the theory of probes in waveguide," *Proc. Inst. Elect. Eng.*, vol. 105, pp. 109–116, Oct. 1958.
- [22] Z. X. Shen and R. H. MacPhie, "A simple method for calculating the reflection coefficient of open-ended waveguides," *IEEE Trans. Microwave Theory Tech.*, vol. 45, pp. 546–548, Apr. 1997.

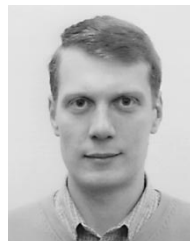

Pavel V. Nikitin (S'98–M'02) was born in Ashkhabad, U.S.S.R., in March 1974. He received the B.S. and M.S. degrees in electrical engineering from Utah State University, Logan, UT, in 1994 and 1998, respectively, the B.S. degree in physics from Novosibirsk State University, Novosibirsk, Russia, in 1995, and the Ph.D. degree in electrical and computer engineering from Carnegie-Mellon University (CMU), Pittsburgh, PA, in 2002.

He was a Research Assistant with the Antenna and Radio Communications Group, Center for Wireless and Broadband Networking, CMU. He is currently a Research Associate with the Department of Electrical Engineering, University of Washington, Seattle. His research interests include applied electromagnetics, wireless communications, and computer-aided design of integrated circuits and systems.

Dr. Nikitin is a member of Phi Kappa Phi. He was a recipient of the 2000 Electrical and Computer Engineering Teaching Assistant of the Year Award presented by CMU.

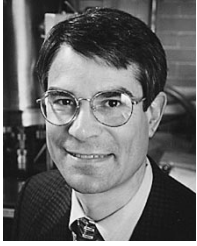

Daniel D. Stancil (S'75–M'81–SM'91) received the B.S. degree in electrical engineering from Tennessee Technological University, Cookeville, in 1976, and the S.M., E.E., and Ph.D. degrees from the Massachusetts Institute of Technology, Cambridge, in 1978, 1979, and 1981, respectively.

From 1981 to 1986, he was an Assistant Professor of electrical and computer engineering from North Carolina State University, Raleigh. In 1986, he became an Associate Professor with Carnegie-Mellon University (CMU), Pittsburgh, PA, where he is currently

a Professor with the Department of Electrical and Computer Engineering, and where he leads the Antenna and Radio Communications Group and heads the newly established Center for Wireless and Broadband Networking. In 1996, he cofounded the Applied Electro-optics Corporation, Pittsburgh, PA. He was a leader in the development of the Virtual Laboratory, Electrical and Computer Engineering Department, CMU, which was a finalist for a 1996 Smithsonian Computerworld Award.

Dr. Stancil was President of the IEEE Magnetics Society. He was the recipient of a 1985 Sigma Xi Research Award presented by North Carolina State University. He was a corecipient of a 1998 Science Award for Excellence presented by the Pittsburgh Carnegie Science Center, an IR 100 Award, and a Photonics Circle of Excellence Award for the development and commercialization of electrooptic technology.



Ahmet G. Cepni (S'01) received the B.S. degrees in electrical and electronics engineering and physics from Bogazici University, Istanbul, Turkey, in 2000, the M.S. degree in electrical and computer engineering from Carnegie-Mellon University (CMU), Pittsburgh, PA, in 2002, and is currently working toward the Ph.D. degree at CMU.

Since January 2001, he has been a Research Assistant with the Antenna and Radio Communications Research Group, CMU. He has been involved with indoor wireless communications via the HVAC duct

project. His research interests are intelligent radio architectures, RF/microwave systems, and propagation models.

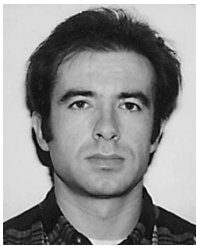

Ariton E. Xhafa (S'98) was born in Karbunar, Vlore, Albania. He received the B.S. degree in electrical and electronics engineering and physics from the Eastern Mediterranean University, North Cyprus, Turkey, in 1997, the M.S. degree in electrical engineering from the State University of New York at Buffalo, in 1999, and is currently working toward the Ph.D. degree in the electrical and computer engineering at Carnegie-Mellon University (CMU), Pittsburgh, PA.

From 2000 to 2001, he was a Visiting Researcher with CMU, where he performed research on design and performance analysis of communication systems. Since 2002, he has been a Research Assistant with the Telecommunications Research Group, CMU. His current research and interests include design and performance analysis of wireless networks, scheduling, resource allocations and queuing theory, and hand-over management and quality of service in communications networks.

Mr. Xhafa is a student member of the IEEE Communications Society, the IEEE Vehicular Technology Society, and the IEEE Computer Society.



Ozan K. Tonguz (S'86–M'89) was born in Cyprus, in May 1960. He received the B.Sc. degree from the University of Essex, Essex, U.K., in 1980, and the M.Sc. and Ph.D. degrees from Rutgers University, New Brunswick, in 1986 and 1990, respectively, all in electrical engineering.

He is currently a Tenured Full Professor with the Department of Electrical and Computer Engineering, Carnegie-Mellon University (CMU), Pittsburgh, PA. Prior to joining CMU in August 2000, he was with the Electrical and Computer Engineering Department, State University of New York at Buffalo (SUNY/Buffalo). In 1990, he

joined SUNY/Buffalo as an Assistant Professor, where he attained early tenure and became an Associate Professor in 1995 and Full Professor in 1998. From 1988 to 1990, he was with Bell Communications Research (Bellcore), where he performed research in optical networks and communication systems. His industrial experience includes periods with Bell Communications Research, CTI Inc., Harris RF Communications, Aria Wireless Systems, Clearwire Technologies, Nokia Networks, and Asea Brown Boveri (ABB). He currently serves as a consultant for several companies, law firms, and government agencies in the U.S. and Europe in the broad area of telecommunications and networking. He is also a Co-Director (Thrust Leader) of the Center for Wireless and Broadband Networking Research, CMU. His current research interests are optical networks, wireless networks and communication systems, high-speed networking, and satellite communications. He has authored or coauthored over 150 technical papers in IEEE journals and conference proceedings and has written a book chapter in the areas of wireless communications, optical networks, satellite communications, and high-speed networking.

Dr. Tonguz serves on the Technical Program Committees (TPCs) of several IEEE conferences and symposia in the area of wireless communications and optical networks. He also currently serves or has served as an associate editor for the IEEE TRANSACTIONS ON COMMUNICATIONS, the IEEE COMMUNICATIONS MAGAZINE, and the JOURNAL OF LIGHTWAVE TECHNOLOGY. He was a guest editor for the 1996 "Special Issue on Multiwavelength Optical Networks and Technology" of the JOURNAL OF LIGHTWAVE TECHNOLOGY AND the IEEE JOURNAL ON SELECTED AREAS IN COMMUNICATIONS.



Dagfin Brodtkorb (M'81) was born in Norway, in July 1947. He received the M.S. and Ph.D. degrees in electrical engineering from the Norwegian Institute of Technology, Trondheim, Norway, in 1970 and in 1976, respectively.

From 1971 to 1980, he was a Research Engineer and Project Manager with the Norwegian Defense Research Establishment, Kjeller, Norway, where he was involved with radar and microwave systems. From 1977 to 1978, he was a Post-Doctoral Researcher with the Lincoln Laboratory, Massachusetts

Institute of Technology, Lexington, where he was involved with surface acoustic wave (SAW) technology. From 1980 to 1984, he was with A/S Informasjonskontroll, Asker, Norway, as a Manager of the Remote Sensing Group. From 1984 to 1995, he was Managing Director of MIROS A/S, Asker, Norway. Since 1995, he has been with the ABB Corporate Research Center, Billingstad, Norway, initially as a Senior Research Manager, then as a Technology Program Manager, and then as a Department Manager. He is currently a Vice President (Research Director) of the ABB Corporate Research Center. He has authored several technical papers.